

LG

THERMA V™

Air-to-Water Heat Pump / Monobloc
R32 / 50Hz
5BPM5-01C(Replaces 5BPM5-01B)

TOTAL HVAC SOLUTION PROVIDER

ENGINEERING PRODUCT DATA BOOK

THERMA VTM
Monobloc Type

General Information

Product Data

Design and installation

THERMA VTM

Monobloc Type

General Information

- 1.Features**
- 2.Model Line Up**
- 3.Nomenclature**

1. Features

- High energy efficiency
- Easy installation
- Total solution for cooling, heating & hot water
- No refrigerant piping work
- Low operating cost and CO₂ emission



< UN4 Chassis >



< UN3 Chassis >

2. Model line up

Category	Chassis	Model Name		
		Capacity (kW)		
		5.5	7.0	9.0
1 Phase Model 1 Ø, 220-240 V, 50 Hz	UN4	ZHBW056A0 [HM051M U43]	ZHBW076A0 [HM071M U43]	ZHBW096A0 [HM091M U43]

Category	Chassis	12.0	14.0	16.0
		1 Phase Model 1 Ø, 220-240 V, 50 Hz	UN3	ZHBW126A0 [HM121M U33]
3 Phase Model 3 Ø, 380-415 V, 50 Hz	ZHBW128A0 [HM123M U33]	ZHBW148A0 [HM143M U33]		ZHBW168A0 [HM163M U33]

3. Nomenclature

■ Global Name

Model Name	ZH	B	W	12	6	A	0
No.	1	2	3	4	5	6	7

No.	Signification
1	ZH : Air-to-Water Heat Pump for R32
2	Classification B : Monobloc
3	Model Type W : Inverter Heat Pump
4	Heating Capacity (kW) Ex) 5 kW : '05', 16 kW : '16'
5	Electrical ratings 6 : 1 Ø, 220-240 V, 50 Hz 8 : 3 Ø, 380-415 V, 50 Hz
6	Function A : General Heating Heat pump
7	Series

3. Nomenclature

■ **European Name**

Model Name	H	M	12	1	M	U3	3
No.	1	2	3	4	5	6	7

No.	Signification
1	H : Air-to-Water Heat Pump
2	Classification M : Monobloc type
3	Heating Capacity (kW) Ex) 5 kW : '05', 16 kW : '16'
4	Electrical ratings 1 : 1 Ø, 220-240 V, 50 Hz 3 : 3 Ø, 380-415 V, 50 Hz
5	Leaving Water Combination M : Mid Temperature
6	Platform (Chassis code) U3 : UN3 Chassis U4 : UN4 Chassis
7	Type of refrigerant 2 : R410A 3 : R32

THERMA VTM

Monobloc Type

Product Data

- 1. List of Functions**
- 2. Specification**
- 3. Dimensions**
- 4. Piping Diagrams**
- 5. Wiring Diagrams**
- 6. Performance Data**
- 7. Electric Characteristics**
- 8. Operation Range**
- 9. Sound levels**
- 10. Water Pump Capacity**

1. List of Functions

■ Basic functions of Unit

◆ Water Side

Category	Functions	ZHBW056A0 [HM051M U43] ZHBW076A0 [HM071M U43] / ZHBW096A0 [HM091M U43] ZHBW126A0 [HM121M U33] / ZHBW128A0 [HM123M U33] ZHBW146A0 [HM141M U33] / ZHBW148A0 [HM143M U33] ZHBW166A0 [HM161M U33] / ZHBW168A0 [HM163M U33]
Installation	Backup heater (Install kit)	O (Accessory)
Reliability	Self diagnosis	O
Convenience	Auto Restart	O
	Child lock	O
	Sleep mode	O
	Timer (on/off)	O
	Timer (weekly)	O
	Two thermistor control	X
Air to Water Heat Pump Functions	Anti-condensation on floor (cooling)	O
	Digital output for external pump	O
	Flow switch	O
	Thermostat interface (230V AC)	O
	Thermostat interface (24V AC)	X
	DHW(Domestic Hot Water) tank kit	O (Accessory)
	Therma V solar kit	O (Accessory)
	PHEX anti-freezing control	O
	Water pump anti-stuck function	O
	Weather compensation for heating and cooling (Auto mode)	O
	Silent operation	O
	Anti-overheating of water pipe	O
	Emergency operation	O
	Weather Dependent Operation with Thermostat	O
	Scheduler (DHW Tank Heater)	O
	Timer (Domestic Hot Water Tank Heater)	O
	Quick Domestic Hot Water Tank Heating	O
	Screed Drying Mode	O
	Sump Heater	O
	Base Pan Heater	O
Integrated Dry Contact (CN-EXT)	O	

◆ Refrigerant Side

Category	Functions	ZHBW056A0 [HM051M U43] ZHBW076A0 [HM071M U43] ZHBW096A0 [HM091M U43] ZHBW126A0 [HM121M U33] ZHBW146A0 [HM141M U33] ZHBW166A0 [HM161M U33]	ZHBW128A0 [HM123M U33] ZHBW148A0 [HM143M U33] ZHBW168A0 [HM163M U33]
Reliability	Defrost / Deicing	O	O
	High pressure switch	O	O
	Low pressure switch	X	X
	Phase protection	X	O
	Restart delay (3-minutes)	O	O
	Self diagnosis	O	O
	Soft start	X	X
Convenience	Test function	X	X
	Wiring Error Check	X	X
	Peak Control	X	X
	Mode Lock	O	O
Network function	Forced Cooling Operation (Outdoor Unit)	X	X
	Network solution(LGAP)	O	O

Note

1. O : Applied, X : Not applied

Accessory : Ordered and purchased separately the accessory package referring to the model name provided and install at field.

Accessory line-ups varies by region, so check your local catalogue or local sales material.

1. List of Functions

■ Accessory Compatibility List

Category		Product	Remark	ZHBW056A0 [HM051M U43] ZHBW076A0 [HM071M U43] ZHBW096A0 [HM091M U43] ZHBW126A0 [HM121M U33] ZHBW146A0 [HM141M U33] ZHBW166A0 [HM161M U33] ZHBW128A0 [HM123M U33] ZHBW148A0 [HM143M U33] ZHBW168A0 [HM163M U33]
Dry Contact	Simple Contact	PDRYCB000	Simple Dry Contact	O
	Communication Type	PDRYCB400	2 Points Dry Contact (For Setback)	X
		PDRYCB300	8 Points Dry Contact (For Thermostat)	O
		PDRYCB500	Dry Contact for Modbus	X
ETC	Remote temperature sensor	PQRSTA0	-	O
	Zone Controller	ABZCA	-	X
	Electronic thermostat	AQETC	-	X
	CTI (Communication transfer interface)	PKEC0	-	X
	Group control wire	PZCWRCG3	0.25 m	X
	2-Remo Control Wire	PZCWRC2	0.25 m	X
	Extension wire	PZCWRC1	10 m	O
	Wi-Fi controller *	PWFMD200	-	O
	Meter Interface Module	PENKTH000	Interface between IDU and Meter	O
Accessory Kit for AWHP	DHW tank kit (Split)	PHLTA	For Split	X
	DHW tank kit (Monobloc)	PHLTB	For Monobloc	O
	Solar thermal kit	PHLLA	-	O
	Backup heater	HA031M E1 / HA061M E1	-	O
	Drain pan	PHDPB	-	X
Central Controller	AC EZ	PQCSZ250S0	AC EZ	X
	AC Ez Touch	PACEZA000	AC Ez Touch	O
	AC Smart	PACS4B000	AC Smart IV	O
		PACS5A000	AC Smart 5	O
	ACP	PACP4B000	ACP IV	O
		PACP5A000	ACP 5	O
	AC Manager **	PACM4B000	AC Manager IV	O
PACM5A000		AC Manager 5	O	
Gateway	IDU PI485	PHNFP14A0	Connected with Indoor Units	X
		PSNFP14A0	Connected with Indoor Units	X
	ODU PI485	PMNFP14A1	PI 485 Gateway	O
	BACnet	PQNFB17C0	ACP BACnet	O
Lonworks	PLNWKB000	ACP Lonworks	O	

Note

1. O: Possible, X: Impossible, - : Not applicable
2. * : Some advanced functions controlled by individual controller cannot be operated.
3. ** : ACP, AC Smart, ACP BACnet or ACP Lonworks is needed.
4. If you need more detail, please refer to the manual of product.
(<http://partner.lge.com/global> : Home> Download> Manuals)

2. Specification

■ 1 phase Inverter (5.5 ~ 9 kW)

Nominal Capacity and Nominal Input					ZHBW056A0 [HM051M U43]	ZHBW076A0 [HM071M U43]	ZHBW096A0 [HM091M U43]
-	-	Outdoor Temp. (°C) DB / WB	Leaving Water Temp. (°C)	-			
Capacity	Cooling	35 / 24	18	kW	5.50	7.00	9.00
			7	kW	5.50	7.00	9.00
	Heating	7 / 6	35	kW	5.50	7.00	9.00
			55	kW	5.50	5.50	5.50
		2 / 1	35	kW	3.30	4.20	5.40
Power Input	Cooling	35 / 24	18	kW	1.20	1.56	2.14
			7	kW	1.96	2.59	3.46
	Heating	7 / 6	35	kW	1.22	1.56	2.15
			55	kW	2.04	2.04	2.04
		2 / 1	35	kW	0.94	1.20	1.54
EER	Cooling	35 / 24	18	W/W	4.60	4.50	4.20
			7	W/W	2.80	2.70	2.60
COP	Heating	7 / 6	35	W/W	4.50	4.50	4.18
			55	W/W	2.70	2.70	2.70
			35	W/W	3.52	3.51	3.50
SCOP (Low temp. Average)					4.45	4.45	4.45
SCOP (High temp. Average)					3.12	3.12	3.12
Rated Water Flow Rate (at LWT 35 °C)				LPM	15.8	20.1	25.9

Electrical Specifications			ZHBW056A0 [HM051M U43]	ZHBW076A0 [HM071M U43]	ZHBW096A0 [HM091M U43]
Power Supply	V, Ø, Hz		220-240, 1, 50	220-240, 1, 50	220-240, 1, 50
Maximum Running Current	A		21.0	22.0	23.0
Peak Control Running Current	A		17.0	17.0	17.0
Rated Running Current	Cooling	A	5.3	6.9	9.5
	Heating	A	5.4	6.9	9.6
Wiring Connections	Power Supply Cable (included Earth, H07RN-F)	No × mm ²	3 × 4.0	3 × 4.0	3 × 4.0

Technical Specifications				ZHBW056A0 [HM051M U43]	ZHBW076A0 [HM071M U43]	ZHBW096A0 [HM091M U43]
Sound Power Level	Heating	Rated	dB(A)	60	60	60
		Silent	dB(A)	58	58	58
Sound Pressure Level (at 1m)	Heating	Rated	dB(A)	50	50	50
Dimensions	Unit	W × H × D	mm	1,239 × 907 × 404	1,239 × 907 × 404	1,239 × 907 × 404
	Packed Unit	W × H × D	mm	1,364 × 1,055 × 461	1,364 × 1,055 × 461	1,364 × 1,055 × 461
Weight	Unit		kg	96.0	96.0	96.0
	Packed Unit		kg	109.0	109.0	109.0

Note

- Due to our policy of innovation some specifications may be changed without notification.
- Wiring cable size must comply with the applicable local and national codes. And "Electric characteristics" chapter should be considered for electrical work and design. Especially the power cable and circuit breaker should be selected in accordance with that.
- Sound pressure level is measured on the rated condition in the anechoic rooms by ISO 3745 standard.
Sound power level is measured on the rated condition in the reverberation rooms by ISO 3741 standard.
Therefore, these values can be increased owing to ambient conditions during operation.
- Performances are accordance with EN14511 and reflect ErP testing conditions. Above gives the declared values at rated conditions acc. ErP regulation.
For max. capacities, refer to Performance Data.
 - Rated running current : Outdoor Temp. 7°CDB / 6°CWB, LWT 35 °C
- This product contains Fluorinated greenhouse gases.
 - * At least 25A circuit breaker can be used, but when using 3rd party product, connect external power.

2. Specification

Technical Specifications (Water side)				ZHBW056A0 [HM051M U43]	ZHBW076A0 [HM071M U43]	ZHBW096A0 [HM091M U43]
Operation Range (Leaving Water Temp.)	Cooling	Min. ~ Max.	°C	5 ~ 27	5 ~ 27	5 ~ 27
	Heating	Min. ~ Max.	°C	15 ~ 65	15 ~ 65	15 ~ 65
	DHW *	Min. ~ Max.	°C	15 ~ 80	15 ~ 80	15 ~ 80
Water Pump	Type	Canned type for hot water circulation				
	Model	GRUNDFOS UPM3K 20-75 CHBL				
	Motor Type	BLDC				
	Steps of Pumping Performance	Variable speed 10% to 100%				
	Power input	Min. / Rated	W	6 / 60	6 / 60	6 / 60
Water Flow Rate	Min. / Rated	ℓ/min	2.3 / 25.9	2.3 / 25.9	2.3 / 25.9	
Heat Exchanger	Type	Brazed Plate HEX				
	Quantity	1				
	Number of Plate	EA	54	54	54	
	Water Volume	ℓ	0.7	0.7	0.7	
Expansion Vessel	Volume	Max.	ℓ	8	8	8
	Water pressure	Max.	bar	3	3	3
		Pre-charged	bar	1	1	1
Piping Connections	Inlet	mm(inch) Male PT 25(1)				
	Outlet	mm(inch) Male PT 25(1)				
Strainer	Mesh size	- 28 mesh 28 mesh 28 mesh				
	Material	- Stainless Steel				
Relief Valve	Pressure Limit	Upper Limit	bar	3.0	3.0	3.0
Devices for Water Circuit	- Relief valve / Flow Switch					
	- Drain hose					
	- Pressure gage / Air vent valve					

Technical Specifications (Refrigerant side)				ZHBW056A0 [HM051M U43]	ZHBW076A0 [HM071M U43]	ZHBW096A0 [HM091M U43]
Operation Range (Outdoor Temp.)	Cooling	Min. ~ Max.	°C DB	5 ~ 48	5 ~ 48	5 ~ 48
	Heating	Min. ~ Max.	°C DB	-25 ~ 35	-25 ~ 35	-25 ~ 35
Compressor	Type	- Hermetic Sealed Scroll				
	Model	Model × No. RJB036MAA × 1				
	Motor Type	- BLDC				
	Displacement	cm ³ /Rev.	31.6	31.6	31.6	
Refrigerant	Type	- R32				
	GWP (Global Warming Potential)	-	675.0	675.0	675.0	
	Precharged Amount	g	1,400	1,400	1,400	
	t-CO2 eq.	-	0.945	0.945	0.945	
	Control	- Electronic Expansion Valve				
Refrigerant Oil	Type	- FW68D				
	Charged Volume	cc × No.	1,000	1,000	1,000	
Fan	Type	- Propeller				
	Air Flow Rate	Rated	m ³ /min × No.	60.0 × 1	60.0 × 1	60.0 × 1
Fan Motor	Type	- BLDC				
	Output	W × No.	124 × 1	124 × 1	124 × 1	

Note

1. Due to our policy of innovation some specifications may be changed without notification.
2. Wiring cable size must comply with the applicable local and national codes. And "Electric characteristics" chapter should be considered for electrical work and design. Especially the power cable and circuit breaker should be selected in accordance with that.
3. Sound pressure level is measured on the rated condition in the anechoic rooms by ISO 3745 standard.
Sound power level is measured on the rated condition in the reverberation rooms by ISO 3741 standard.
Therefore, these values can be increased owing to ambient conditions during operation.
4. Performances are accordance with EN14511 and reflect ErP testing conditions. Above gives the declared values at rated conditions acc. ErP regulation.
For max. capacities, refer to Performance Data.
 - Rated running current : Outdoor Temp. 7°CDB / 6°CWB, LWT 35°C
5. This product contains Fluorinated greenhouse gases.
 - * DHW 55~80°C Operating is available only when the booster heater is operating.

2. Specification

■ 1 phase Inverter (12 ~ 16 kW)

Nominal Capacity and Nominal Input					ZHBW126A0 [HM121M U33]	ZHBW146A0 [HM141M U33]	ZHBW166A0 [HM161M U33]	
-	-	Outdoor Temp. (°C) DB / WB	Leaving Water Temp. (°C)	-				
Capacity	Cooling	35 / 24	18	kW	12.00	14.00	16.00	
			7	kW	12.00	14.00	16.00	
	Heating	7 / 6	35	kW	12.00	14.00	16.00	
			55	kW	12.00	12.00	12.00	
		2 / 1	35	kW	11.00	12.00	13.80	
Power Input	Cooling	35 / 24	18	kW	2.61	3.26	4.00	
			7	kW	4.44	5.38	6.40	
	Heating	7 / 6	35	kW	2.61	3.11	3.64	
			55	kW	4.29	4.29	4.29	
			2 / 1	35	kW	3.13	3.42	3.94
	EER	Cooling	35 / 24	18	W/W	4.60	4.30	4.00
7				W/W	2.70	2.60	2.50	
COP	Heating	7 / 6	35	W/W	4.60	4.50	4.40	
			55	W/W	2.80	2.80	2.80	
		2 / 1	35	W/W	3.52	3.51	3.50	
SCOP (Low temp. Average)					4.45	4.45	4.45	
SCOP (High temp. Average)					3.18	3.18	3.18	
Rated Water Flow Rate (at LWT 35 °C)				LPM	34.5	40.3	46.0	

Electrical Specifications			ZHBW126A0 [HM121M U33]	ZHBW146A0 [HM141M U33]	ZHBW166A0 [HM161M U33]
Power Supply	V, Ø, Hz		220-240, 1, 50	220-240, 1, 50	220-240, 1, 50
Maximum Running Current	A		33.0	34.0	35.0
Peak Control Running Current	A		25.0	25.0	25.0
Rated Running Current	Cooling	A	11.6	14.4	17.7
	Heating	A	11.6	13.8	16.1
Wiring Connections	Power Supply Cable (included Earth, H07RN-F)	No × mm ²	3 × 6.0	3 × 6.0	3 × 6.0

Technical Specifications				ZHBW126A0 [HM121M U33]	ZHBW146A0 [HM141M U33]	ZHBW166A0 [HM161M U33]
Sound Power Level	Heating	Rated	dB(A)	63	63	63
		Silent	dB(A)	61	61	61
Sound Pressure Level (at 1m)	Heating	Rated	dB(A)	52	52	52
Dimensions	Unit	W × H × D	mm	1,239 × 1,450 × 404	1,239 × 1,450 × 404	1,239 × 1,450 × 404
	Packed Unit	W × H × D	mm	1,364 × 1,602 × 461	1,364 × 1,602 × 461	1,364 × 1,602 × 461
Weight	Unit		kg	130.0	130.0	130.0
	Packed Unit		kg	145.0	145.0	145.0

Note

1. Due to our policy of innovation some specifications may be changed without notification.
2. Wiring cable size must comply with the applicable local and national codes. And "Electric characteristics" chapter should be considered for electrical work and design. Especially the power cable and circuit breaker should be selected in accordance with that.
3. Sound pressure level is measured on the rated condition in the anechoic rooms by ISO 3745 standard.
Sound power level is measured on the rated condition in the reverberation rooms by ISO 3741 standard.
Therefore, these values can be increased owing to ambient conditions during operation.
4. Performances are accordance with EN14511 and reflect ErP testing conditions. Above gives the declared values at rated conditions acc. ErP regulation.
For max. capacities, refer to Performance Data.
 - Rated running current : Outdoor Temp. 7°CDB / 6°CWB, LWT 35 °C
5. This product contains Fluorinated greenhouse gases.
 - * At least 40A circuit breaker can be used, but when using 3rd party product, connect external power.

2. Specification

Technical Specifications (Water side)				ZHBW126A0 [HM121M U33]	ZHBW146A0 [HM141M U33]	ZHBW166A0 [HM161M U33]
Operation Range (Leaving Water Temp.)	Cooling	Min. ~ Max.	°C	5 ~ 27	5 ~ 27	5 ~ 27
	Heating	Min. ~ Max.	°C	15 ~ 65	15 ~ 65	15 ~ 65
	DHW *	Min. ~ Max.	°C	15 ~ 80	15 ~ 80	15 ~ 80
Water Pump	Type	Canned type for hot water circulation				
	Model	GRUNDFOS UPML GEO 20-105 CHBL				
	Motor Type	BLDC				
	Steps of Pumping Performance	Variable speed 10% to 100%				
	Power input	Min. / Rated	W	14 / 140	14 / 140	14 / 140
	Water Flow Rate	Min. / Rated	ℓ/min	5.0 / 46.0	5.0 / 46.0	5.0 / 46.0
Heat Exchanger	Type	Braze Plate HEX				
	Quantity	1				
	Number of Plate	EA 76				
	Water Volume	ℓ 1.0				
Expansion Vessel	Volume	Max.	ℓ	8	8	8
		Water pressure	Max.	bar	3	3
			Pre-charged	bar	1	1
Piping Connections	Inlet	mm(inch) Male PT 25(1)				
	Outlet	mm(inch) Male PT 25(1)				
Strainer	Mesh size	- 28 mesh				
	Material	- Stainless Steel				
Relief Valve	Pressure Limit	Upper Limit	bar	3.0	3.0	3.0
		- Relief valve / Flow Switch				
Devices for Water Circuit	- Drain hose					
	- Pressure gage / Air vent valve					

Technical Specifications (Refrigerant side)				ZHBW126A0 [HM121M U33]	ZHBW146A0 [HM141M U33]	ZHBW166A0 [HM161M U33]
Operation Range (Outdoor Temp.)	Cooling	Min. ~ Max.	°C DB	5 ~ 48	5 ~ 48	5 ~ 48
	Heating	Min. ~ Max.	°C DB	-25 ~ 35	-25 ~ 35	-25 ~ 35
Compressor	Type	- Hermetic Sealed Scroll				
	Model	Model × No. RJB036MAA × 1				
	Motor Type	- BLDC				
	Displacement	cm ³ /Rev. 31.6				
Refrigerant	Type	- R32				
	GWP (Global Warming Potential)	- 675.0				
	Precharged Amount	g 2,400				
	t-CO2 eq.	- 1.620				
	Control	- Electronic Expansion Valve				
Refrigerant Oil	Type	- FW68D				
	Charged Volume	cc × No. 1,000				
Fan	Type	- Propeller				
	Air Flow Rate	Rated	m ³ /min × No.	60.0 × 2	60.0 × 2	60.0 × 2
Fan Motor	Type	- BLDC				
	Output	W × No. 124 × 2				

Note

1. Due to our policy of innovation some specifications may be changed without notification.
2. Wiring cable size must comply with the applicable local and national codes. And "Electric characteristics" chapter should be considered for electrical work and design. Especially the power cable and circuit breaker should be selected in accordance with that.
3. Sound pressure level is measured on the rated condition in the anechoic rooms by ISO 3745 standard.
Sound power level is measured on the rated condition in the reverberation rooms by ISO 3741 standard.
Therefore, these values can be increased owing to ambient conditions during operation.
4. Performances are accordance with EN14511 and reflect ErP testing conditions. Above gives the declared values at rated conditions acc. ErP regulation.
For max. capacities, refer to Performance Data.
 - Rated running current : Outdoor Temp. 7°CDB / 6°CWB, LWT 35°C
5. This product contains Fluorinated greenhouse gases.
 - * DHW 55~80°C Operating is available only when the booster heater is operating.

2. Specification

■ 3 phase Inverter (12 ~ 16 kW)

Nominal Capacity and Nominal Input					ZHBW128A0 [HM123M U33]	ZHBW148A0 [HM143M U33]	ZHBW168A0 [HM163M U33]	
-	-	Outdoor Temp (°C) DB / WB	Leaving Waer Temp (°C)	-				
Capacity	Cooling	35 / 24	18	kW	12.00	14.00	16.00	
			7	kW	12.00	14.00	16.00	
	Heating	7 / 6	35	kW	12.00	14.00	16.00	
			55	kW	12.00	12.00	12.00	
		2 / 1	35	kW	11.00	12.00	13.80	
Power Input	Cooling	35 / 24	18	kW	2.61	3.26	4.00	
			7	kW	4.44	5.38	6.40	
	Heating	7 / 6	35	kW	2.61	3.11	3.64	
			55	kW	4.29	4.29	4.29	
			2 / 1	35	kW	3.13	3.42	3.94
	EER	Cooling	35 / 24	18	W/W	4.60	4.30	4.00
7				W/W	2.70	2.60	2.50	
COP	Heating	7 / 6	35	W/W	4.60	4.50	4.40	
			55	W/W	2.80	2.80	2.80	
		2 / 1	35	W/W	3.52	3.51	3.50	
SCOP (Low temp. Average)					4.45	4.45	4.45	
SCOP (High temp. Average)					3.18	3.18	3.18	
Rated Water Flow Rate (at LWT 35 °C)				LPM	34.5	40.3	46.0	

Electrical Specifications			ZHBW128A0 [HM123M U33]	ZHBW148A0 [HM143M U33]	ZHBW168A0 [HM163M U33]
Power Supply	V, Ø, Hz		380-415, 3, 50	380-415, 3, 50	380-415, 3, 50
Maximum Running Current	A		14.0	14.5	15.0
Peak Control Running Current	A		10.0	10.0	10.0
Rated Running Current	Cooling	A	3.8	4.8	5.9
	Heating	A	3.8	4.6	5.4
Wiring Connections	Power Supply Cable (included Earth, H07RN-F)	No × mm ²	5 × 4.0	5 × 4.0	5 × 4.0

Technical Specifications				ZHBW128A0 [HM123M U33]	ZHBW148A0 [HM143M U33]	ZHBW168A0 [HM163M U33]
Sound Power Level	Heating	Rated	dB(A)	63	63	63
		Silent	dB(A)	61	61	61
Sound Pressure Level (at 1m)	Heating	Rated	dB(A)	52	52	52
Dimensions	Unit	W × H × D	mm	1,239 × 1,450 × 404	1,239 × 1,450 × 404	1,239 × 1,450 × 404
	Packed Unit	W × H × D	mm	1,364 × 1,602 × 461	1,364 × 1,602 × 461	1,364 × 1,602 × 461
Weight	Unit		kg	130.0	130.0	130.0
	Packed Unit		kg	145.0	145.0	145.0

Note

1. Due to our policy of innovation some specifications may be changed without notification.
2. Wiring cable size must comply with the applicable local and national codes. And "Electric characteristics" chapter should be considered for electrical work and design. Especially the power cable and circuit breaker should be selected in accordance with that.
3. Sound pressure level is measured on the rated condition in the anechoic rooms by ISO 3745 standard.
Sound power level is measured on the rated condition in the reverberation rooms by ISO 3741 standard.
Therefore, these values can be increased owing to ambient conditions during operation.
4. Performances are accordance with EN14511 and reflect ErP testing conditions. Above gives the declared values at rated conditions acc. ErP regulation.
For max. capacities, refer to Performance Data.
 - Rated running current : Outdoor Temp. 7°CDB / 6°CWB, LWT 35 °C
5. This product contains Fluorinated greenhouse gases.
 - * At least 20A circuit breaker can be used, but when using 3rd party product, connect external power.

2. Specification

Technical Specifications (Water side)				ZHBW128A0 [HM123M U33]	ZHBW148A0 [HM143M U33]	ZHBW168A0 [HM163M U33]
Operation Range (Leaving Water Temp.)	Cooling	Min. ~ Max.	°C	5 ~ 27	5 ~ 27	5 ~ 27
	Heating	Min. ~ Max.	°C	15 ~ 65	15 ~ 65	15 ~ 65
	DHW *	Min. ~ Max.	°C	15 ~ 80	15 ~ 80	15 ~ 80
Water Pump	Type	Canned type for hot water circulation				
	Model	GRUNDFOS UPML GEO 20-105 CHBL				
	Motor Type	BLDC				
	Steps of Pumping Performance	Variable speed 10% to 100%				
	Power input	Min. / Rated	W	14 / 140	14 / 140	14 / 140
	Water Flow Rate	Min. / Rated	ℓ/min	5.0 / 46.0	5.0 / 46.0	5.0 / 46.0
Heat Exchanger	Type	Braze Plate HEX				
	Quantity	1				
	Number of Plate	EA	76	76	76	
	Water Volume	ℓ	1.0	1.0	1.0	
Expansion Vessel	Volume	Max.	ℓ	8	8	8
		Max.	bar	3	3	3
	Water pressure	Pre-charged	bar	1	1	1
Piping Connections	Inlet	mm(inch)				
	Outlet	mm(inch)				
Strainer	Mesh size	-				
	Material	-				
Relief Valve	Pressure Limit	Upper Limit	bar	3.0	3.0	3.0
	Devices for Water Circuit			-	Relief valve / Flow Switch	
			-	Drain hose		
			-	Pressure gage / Air vent valve		

Technical Specifications (Refrigerant side)				ZHBW128A0 [HM123M U33]	ZHBW148A0 [HM143M U33]	ZHBW168A0 [HM163M U33]
Operation Range (Outdoor Temp.)	Cooling	Min. ~ Max.	°C DB	5 ~ 48	5 ~ 48	5 ~ 48
	Heating	Min. ~ Max.	°C DB	-25 ~ 35	-25 ~ 35	-25 ~ 35
Compressor	Type	-				
	Model	Model × No.				
	Motor Type	-				
	Displacement	cm ³ /Rev.	31.6	31.6	31.6	
Refrigerant	Type	-				
	GWP (Global Warming Potential)	-				
	Precharged Amount	g	2,400	2,400	2,400	
	t-CO2 eq.	-	1.620	1.620	1.620	
	Control	-				
Refrigerant Oil	Type	-				
	Charged Volume	cc × No.	1,000	1,000	1,000	
Fan	Type	-				
	Air Flow Rate	Rated	m ³ /min × No.	60.0 × 2	60.0 × 2	60.0 × 2
Fan Motor	Type	-				
	Output	W × No.	124 × 2	124 × 2	124 × 2	

Note

- Due to our policy of innovation some specifications may be changed without notification.
- Wiring cable size must comply with the applicable local and national codes. And "Electric characteristics" chapter should be considered for electrical work and design. Especially the power cable and circuit breaker should be selected in accordance with that.
- Sound pressure level is measured on the rated condition in the anechoic rooms by ISO 3745 standard.
Sound power level is measured on the rated condition in the reverberation rooms by ISO 3741 standard.
Therefore, these values can be increased owing to ambient conditions during operation.
- Performances are accordance with EN14511 and reflect ErP testing conditions. Above gives the declared values at rated conditions acc. ErP regulation.
For max. capacities, refer to Performance Data.
 - Rated running current : Outdoor Temp. 7°CDB / 6°CWB, LWT 35°C
- This product contains Fluorinated greenhouse gases.
 - * DHW 55~80°C Operating is available only when the booster heater is operating.

2. Specification

■ Backup Heater

Electrical Specification			AHEH036A [HA031M E1]	AHEH066A [HA061M E1]
Backup Heater	Type	-	Sheath	Sheath
	Number of Heating Coil	EA	1	2
	Max. Power consumption	kW	3.0	3.0 + 3.0
	Operation	-	Automatic	Automatic
	Heating Steps	Step	1	2
	Power Supply	V, Ø, Hz	220-240, 1, 50	220-240, 1, 50
Wiring Connections	Power Cable (Included Earth, H07RN-F)	No. × mm ²	3 × 1.5	3 × 4.0
	Communication Cable (H07RN-F)	No. × mm ²	4 × 0.75	4 × 0.75

Note

1. Due to our policy of innovation some specifications may be changed without notification.
2. Wiring cable size must comply with the applicable local and national codes. And "Electric characteristics" chapter should be considered for electrical work and design. Especially the power cable and circuit breaker should be selected in accordance with that.

3. Dimensions

Product

◆ ZHBW056A0 [HM051M U43] / ZHBW076A0 [HM071M U43] / ZHBW096A0 [HM091M U43]

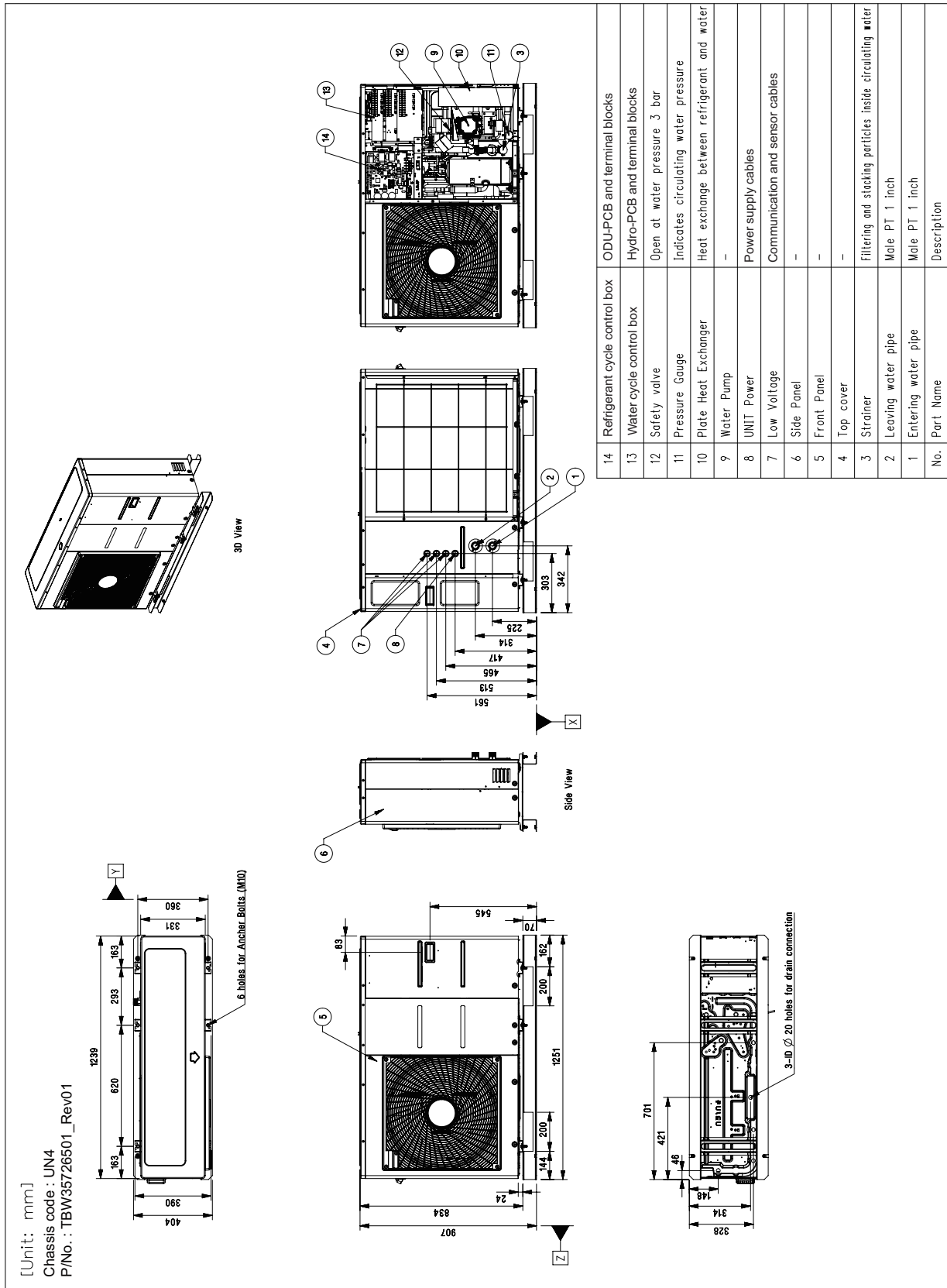

3. Dimensions

- ◆ ZHBW126A0 [HM121M U33] / ZHBW146A0 [HM141M U33] / ZHBW166A0 [HM161M U33]
 ZHBW128A0 [HM123M U33] / ZHBW148A0 [HM143M U33] / ZHBW168A0 [HM163M U33]

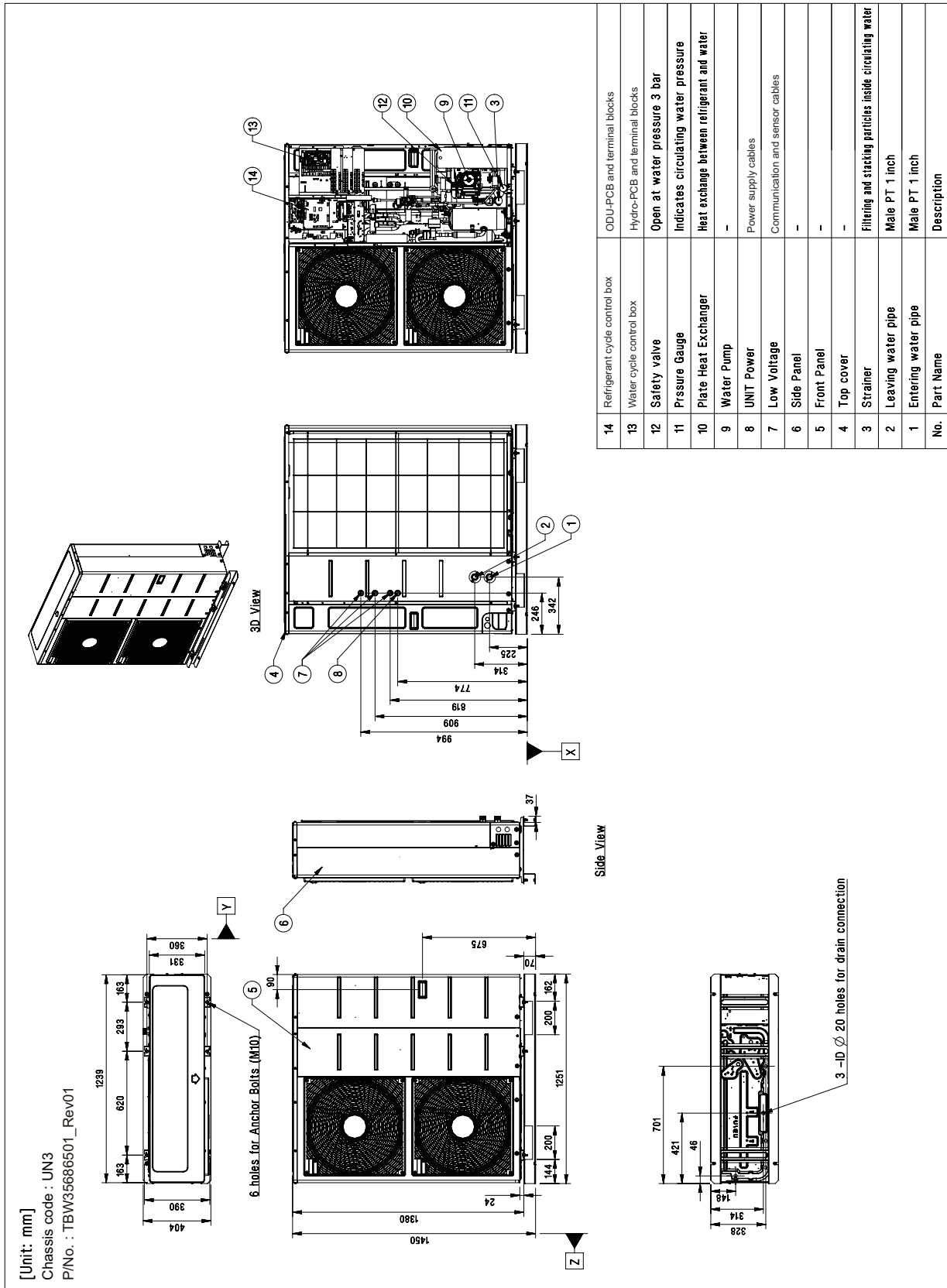

3. Dimensions

Backup Heater

Accessory(Backup Heater)

Note

- Unit should be installed in compliance with the installation manual in the product box.
- Unit should be grounded in accordance with the local regulations or applicable national codes.
- All electrical components and materials to be supplied from the site must comply with the local regulations or international codes.

[Unit: mm]

P/No.: TAY37568301

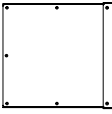

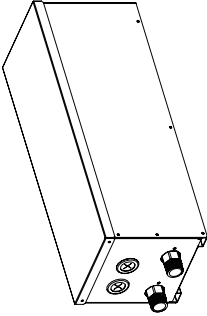

Side View

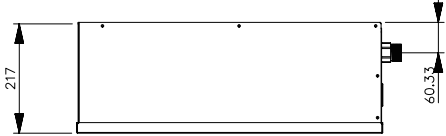
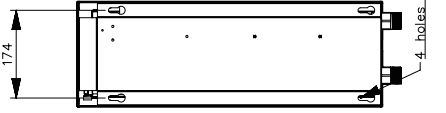
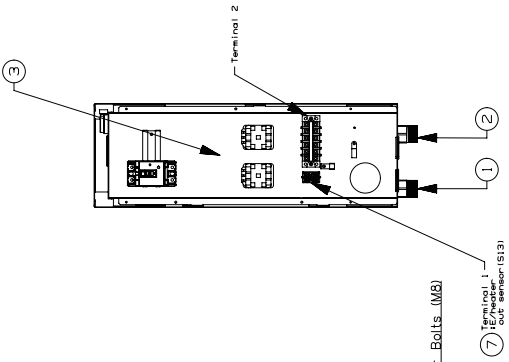
Side View

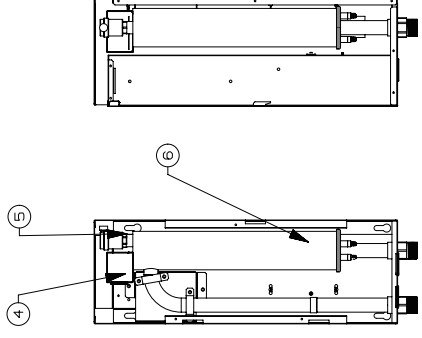

Side View

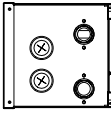

No.	Part Name	Description
7	Backup heater outlet sensor(S/S)	Connect to unit heat pump
6	Electric Heater	Refer the related information
5	Air vent	Air purging when charging water
4	Thermal switch	Cut-off power input to E/Heater at 90℃
3	Control Box	Circuit Breaker, Magnetic Switch, Terminal Blocks
2	Entering Water Pipe	Male PT 1 inch
1	Leaving Water Pipe	Male PT 1 inch

4. Piping Diagram

◆ ZHBW056A0 [HM051M U43] / ZHBW076A0 [HM071M U43] / ZHBW096A0 [HM091M U43]

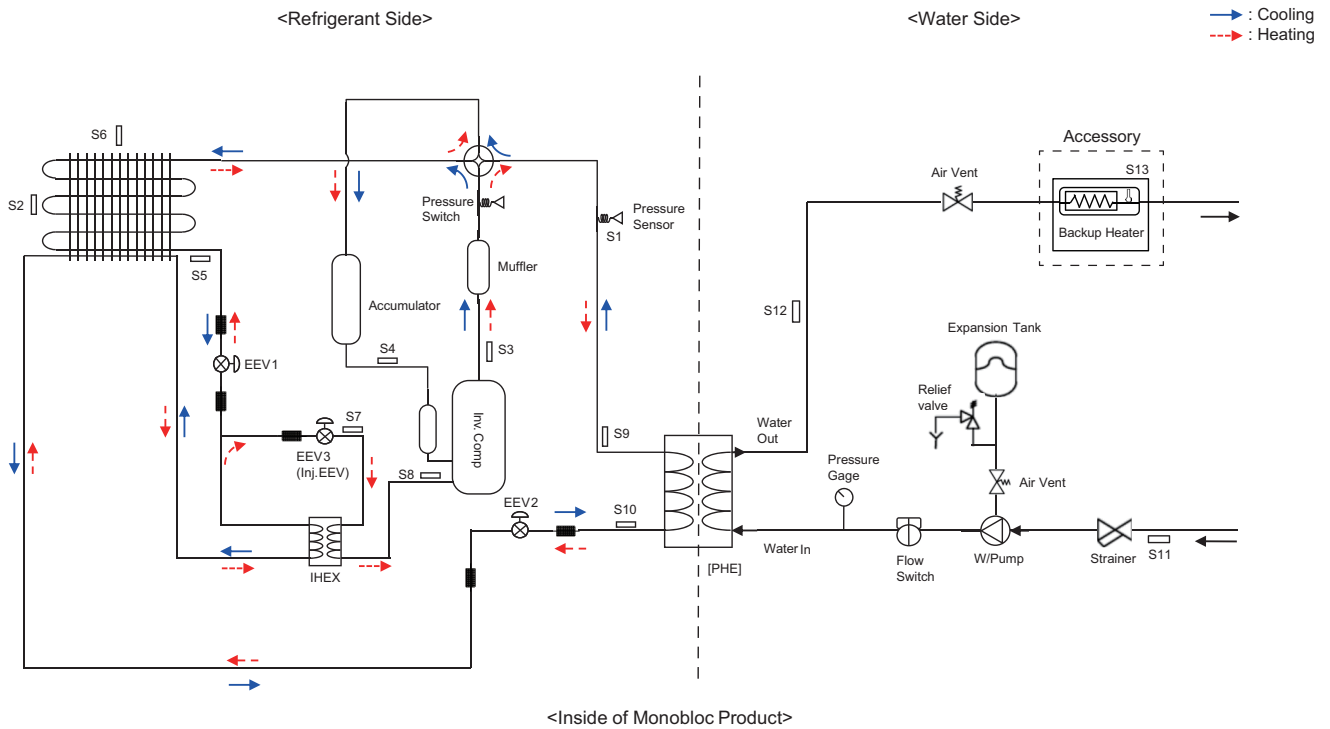

Category	Symbol	Meaning	PCB Connector
Refrigerant side	S9	PHEX gas temp. sensor	CN_PIPE/OUT
	S10	PHEX liquid temp. sensor	CN_PIPE/IN
	S7	Inlet IHEX temperature sensor	CN_VI_IN
	S8	Outlet IHEX temperature sensor	CN_VI_OUT
	S3	Compressor-discharge pipe temperature sensor	CN_DISCHA
	S4	Compressor-suction pipe temperature sensor	CN_SUCTION
	S2	Outdoor-HEX middle temp. sensor	CN_MID
	S5	Outdoor-HEX temp. sensor	CN_C_PIPE
	S6	Outdoor air temperature sensor	CN_AIR
	EEV1	Electronic Expansion Valve (Heating)	CN_EEV1(WH)
	EEV2	Electronic Expansion Valve (Cooling)	CN_EEV2(BL)
Water Side	S11	Inlet water temperature sensor	CN_TH3
	S12	Outlet water temperature sensor	
	S13	Electric backup heater outlet (Accessory kit)	

4. Piping Diagram

- ◆ ZHBW126A0 [HM121M U33] / ZHBW146A0 [HM141M U33] / ZHBW166A0 [HM161M U33]
 ZHBW128A0 [HM123M U33] / ZHBW148A0 [HM143M U33] / ZHBW168A0 [HM163M U33]

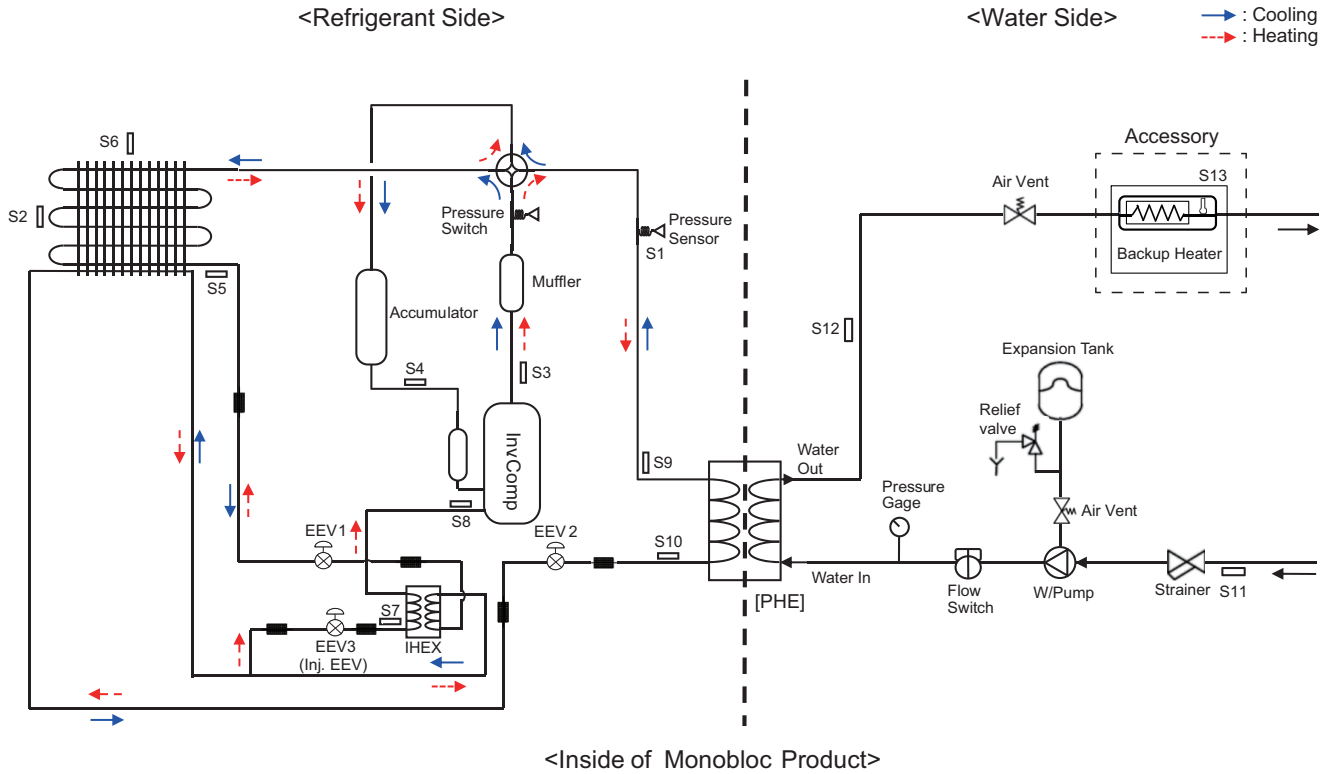

Category	Symbol	Meaning	PCB Connector
Refrigerant side	S9	PHEX gas temp. sensor	CN_PIPE/OUT
	S10	PHEX liquid temp. sensor	CN_PIPE/IN
	S7	Inlet IHEX temperature sensor	CN_VI_IN
	S8	Outlet IHEX temperature sensor	CN_VI_OUT
	S3	Compressor-discharge pipe temperature sensor	CN_DISCHA
	S4	Compressor-suction pipe temperature sensor	CN_SUCTION
	S2	Outdoor-HEX middle temp. sensor	CN_MID
	S5	Outdoor-HEX temp. sensor	CN_C_PIPE
	S6	Outdoor air temperature sensor	CN_AIR
	EEV1	Electronic Expansion Valve (Heating)	CN_EEV1_WH
EEV2	Electronic Expansion Valve (Cooling)	CN_EEV2_BL	
EEV3	Electronic Expansion Valve (Injection)	CN_EEV_MAIN_VI	
Water Side	S11	Inlet water temperature sensor	CN_TH3
	S12	Outlet water temperature sensor	
	S13	Electric backup heater outlet (Accessory kit)	

5. Wiring Diagram

◆ ZHBW056A0 [HM051M U43] / ZHBW076A0 [HM071M U43] / ZHBW096A0 [HM091M U43]

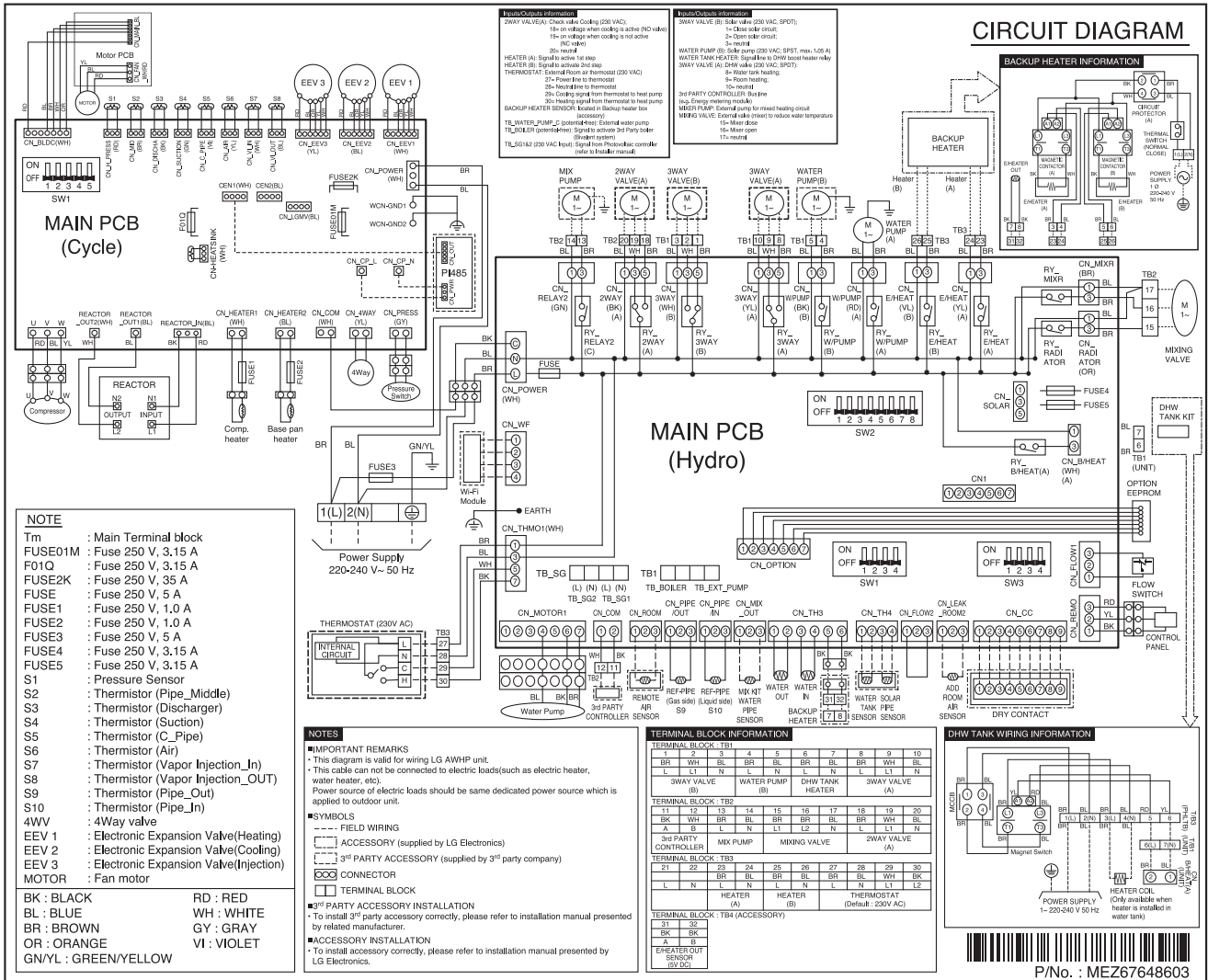

P/No. : MEZ6748603

5. Wiring Diagram

◆ ZHBW126A0 [HM121M U33] / ZHBW146A0 [HM141M U33] / ZHBW166A0 [HM161M U33]

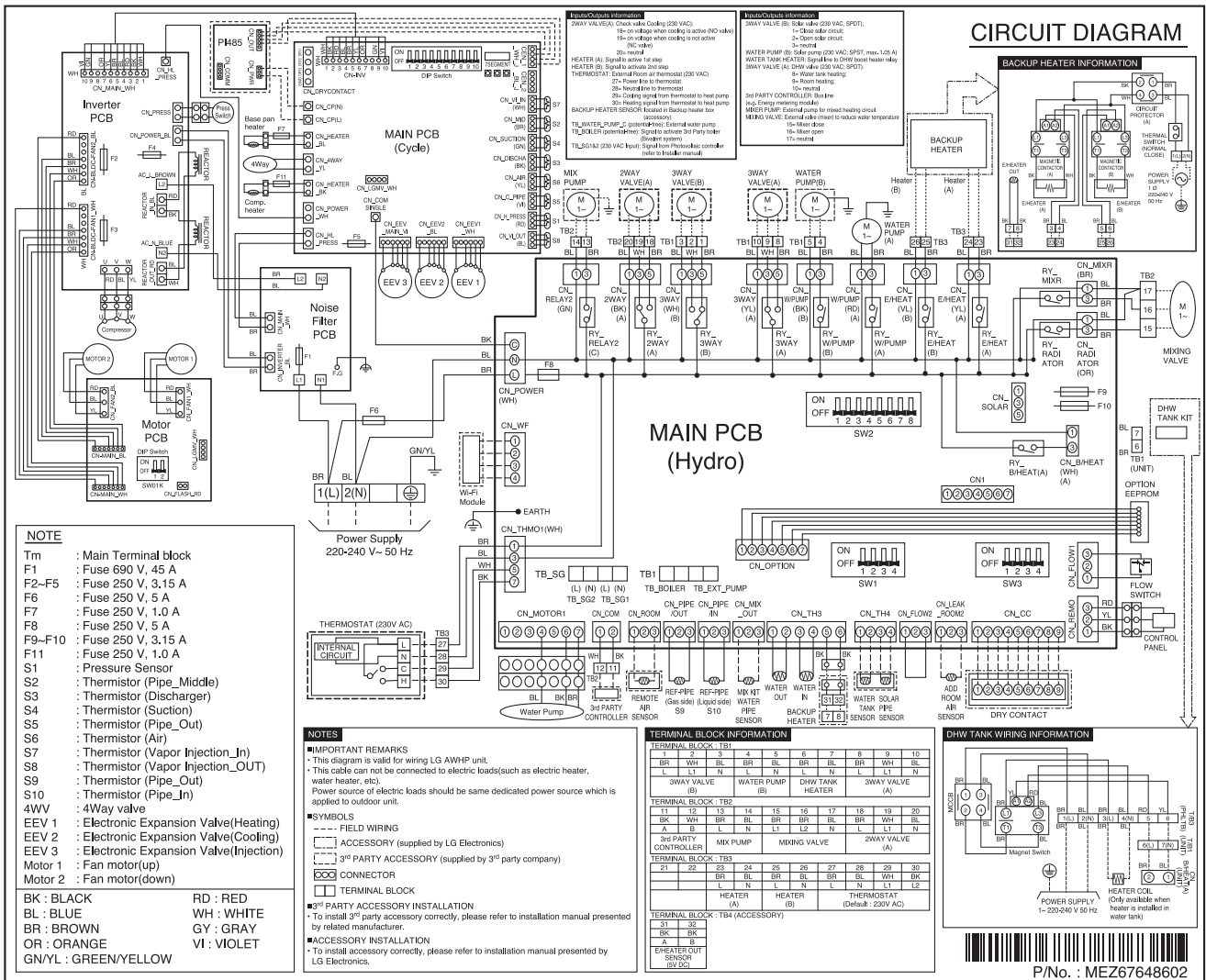

5. Wiring Diagram

◆ ZHBW128A0 [HM123M U33] / ZHBW148A0 [HM143M U33] / ZHBW168A0 [HM163M U33]

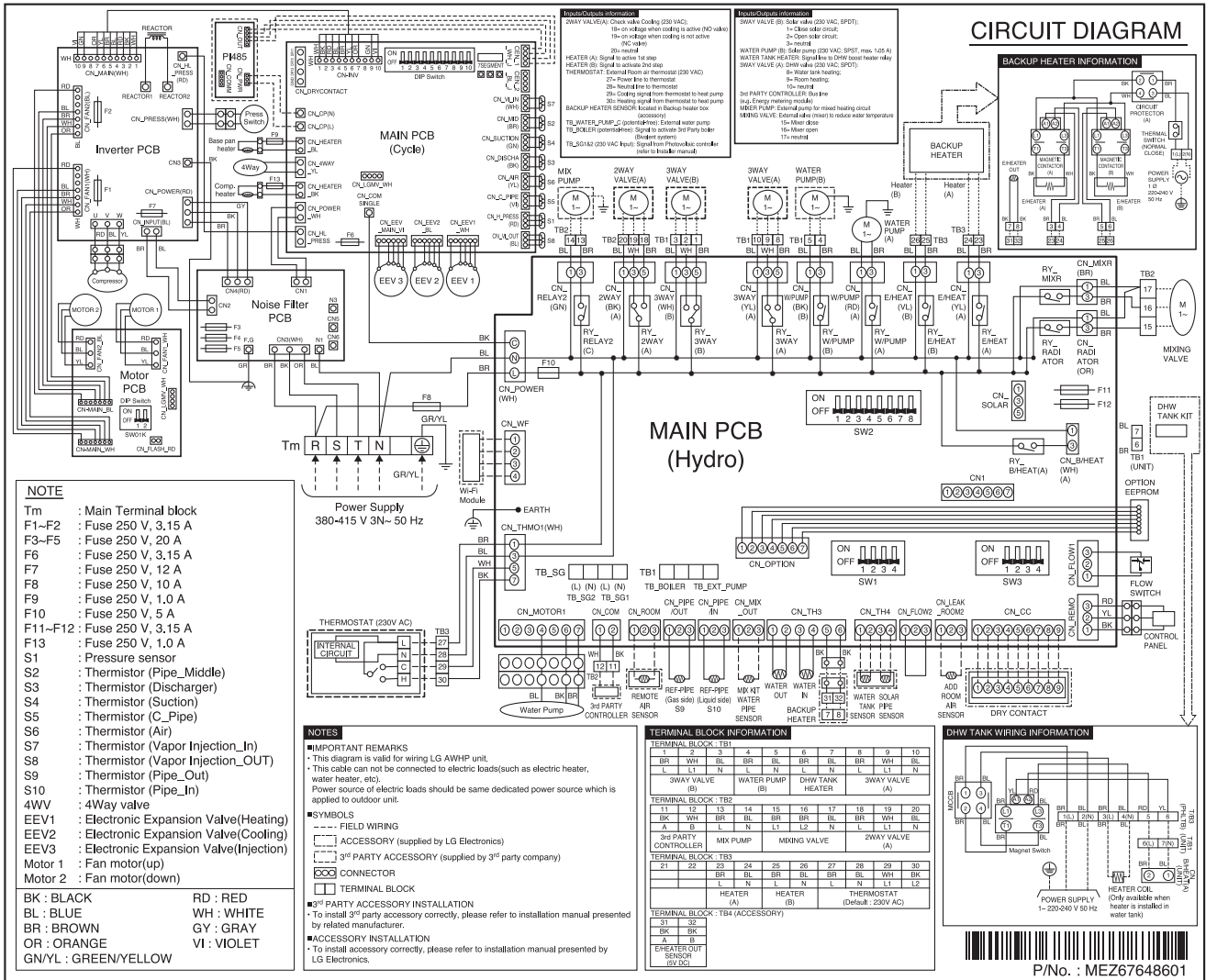

6. Performance Data

6.1 Cooling Operation

■ Maximum Cooling Capacity

◆ ZHBW056A0 [HM051M U43]

Outdoor Temperature [°C DB]	Water flow rate 15.8 LPM													
	LWT 7 °C		LWT 10 °C		LWT 13 °C		LWT 15 °C		LWT 18 °C		LWT 20 °C		LWT 22 °C	
	TC	COP	TC	COP	TC	COP	TC	COP	TC	COP	TC	COP	TC	COP
10	5.16	4.43	5.65	4.86	6.14	5.29	6.47	5.58	6.96	6.01	7.29	6.30	7.62	6.59
20	5.29	3.78	5.59	4.23	5.89	4.69	6.08	4.99	6.38	5.45	6.58	5.75	6.77	6.05
30	5.43	3.13	5.53	3.60	5.63	4.08	5.69	4.40	5.79	4.88	5.86	5.20	5.92	5.52
35	5.50	2.80	5.50	3.29	5.50	3.78	5.50	4.11	5.50	4.60	5.50	4.93	5.50	5.25
40	5.57	2.47	5.50	2.95	5.43	3.42	5.38	3.74	5.31	4.21	5.27	4.52	5.22	4.84
45	5.64	2.15	5.50	2.60	5.36	3.06	5.27	3.36	5.13	3.82	5.04	4.12	4.94	4.42

◆ ZHBW076A0 [HM071M U43]

Outdoor Temperature [°C DB]	Water flow rate 20.1 LPM													
	LWT 7 °C		LWT 10 °C		LWT 13 °C		LWT 15 °C		LWT 18 °C		LWT 20 °C		LWT 22 °C	
	TC	COP	TC	COP	TC	COP	TC	COP	TC	COP	TC	COP	TC	COP
10	6.56	4.33	7.19	4.75	7.82	5.18	8.24	5.46	8.86	5.88	9.28	6.16	9.70	6.44
20	6.74	3.68	7.11	4.13	7.49	4.58	7.74	4.88	8.12	5.33	8.37	5.63	8.62	5.93
30	6.91	3.03	7.04	3.50	7.16	3.98	7.25	4.30	7.37	4.78	7.46	5.09	7.54	5.41
35	7.00	2.70	7.00	3.19	7.00	3.68	7.00	4.01	7.00	4.50	7.00	4.83	7.00	5.15
40	7.09	2.37	7.00	2.85	6.91	3.32	6.85	3.63	6.76	4.10	6.70	4.42	6.65	4.73
45	7.18	2.05	7.00	2.50	6.82	2.95	6.70	3.25	6.53	3.70	6.41	4.01	6.29	4.31

◆ ZHBW096A0 [HM091M U43]

Outdoor Temperature [°C DB]	Water flow rate 25.9 LPM													
	LWT 7 °C		LWT 10 °C		LWT 13 °C		LWT 15 °C		LWT 18 °C		LWT 20 °C		LWT 22 °C	
	TC	COP	TC	COP	TC	COP	TC	COP	TC	COP	TC	COP	TC	COP
10	8.44	4.04	9.24	4.44	10.05	4.83	10.59	5.09	11.40	5.49	11.93	5.75	12.47	6.01
20	8.66	3.47	9.15	3.88	9.63	4.29	9.95	4.56	10.44	4.97	10.76	5.25	11.08	5.52
30	8.89	2.89	9.05	3.32	9.21	3.74	9.32	4.03	9.48	4.46	9.59	4.74	9.69	5.03
35	9.00	2.60	9.00	3.04	9.00	3.47	9.00	3.76	9.00	4.20	9.00	4.49	9.00	4.78
40	9.11	2.31	9.00	2.73	8.89	3.16	8.81	3.44	8.70	3.86	8.62	4.14	8.54	4.42
45	9.23	2.02	9.00	2.43	8.77	2.84	8.62	3.11	8.39	3.52	8.24	3.79	8.09	4.06

Note

1. DB : Dry bulb temperature(°C), LWT : Leaving water temperature(°C), LPM : Liters per minute (ℓ/min)
2. TC : Total capacity(kW), COP : Coefficient of performance (kW/kW)
3. Direct interpolation is permissible. Do not extrapolate.
4. Measuring procedure follows EN-14511.
 - Rated values are based on standard conditions, and it can be found on specifications.
 - Above table values may not be matched according to installation condition. Except for rated value, the performance is not guaranteed.
 - In accordance with the test standard(or nations), the results may vary.

6. Performance Data

◆ ZHBW126A0 [HM121M U33] / ZHBW128A0 [HM123M U33]

Outdoor Temperature [°C DB]	Water flow rate 34.5 LPM													
	LWT 7 °C		LWT 10 °C		LWT 13 °C		LWT 15 °C		LWT 18 °C		LWT 20 °C		LWT 22 °C	
	TC	COP	TC	COP	TC	COP	TC	COP	TC	COP	TC	COP	TC	COP
10	11.25	4.43	12.33	4.86	13.40	5.29	14.12	5.58	15.20	6.01	15.91	6.30	16.63	6.59
20	11.55	3.74	12.20	4.20	12.84	4.67	13.27	4.98	13.92	5.45	14.35	5.76	14.78	6.07
30	11.85	3.05	12.07	3.55	12.28	4.05	12.42	4.38	12.64	4.88	12.78	5.22	12.93	5.55
35	12.00	2.70	12.00	3.22	12.00	3.74	12.00	4.08	12.00	4.60	12.00	4.95	12.00	5.29
40	12.15	2.35	12.00	2.85	11.85	3.35	11.75	3.68	11.59	4.17	11.49	4.50	11.39	4.83
45	12.30	2.01	12.00	2.48	11.69	2.95	11.49	3.27	11.19	3.74	10.99	4.06	10.78	4.37

◆ ZHBW146A0 [HM141M U33] / ZHBW148A0 [HM143M U33]

Outdoor Temperature [°C DB]	Water flow rate 40.3 LPM													
	LWT 7 °C		LWT 10 °C		LWT 13 °C		LWT 15 °C		LWT 18 °C		LWT 20 °C		LWT 22 °C	
	TC	COP	TC	COP	TC	COP	TC	COP	TC	COP	TC	COP	TC	COP
10	13.13	4.14	14.38	4.54	15.64	4.95	16.47	5.22	17.73	5.62	18.57	5.89	19.40	6.16
20	13.48	3.52	14.23	3.95	14.98	4.38	15.48	4.66	16.24	5.09	16.74	5.38	17.24	5.66
30	13.83	2.91	14.08	3.36	14.33	3.81	14.49	4.11	14.75	4.56	14.91	4.87	15.08	5.17
35	14.00	2.60	14.00	3.06	14.00	3.53	14.00	3.84	14.00	4.30	14.00	4.61	14.00	4.92
40	14.18	2.29	14.00	2.74	13.82	3.18	13.70	3.48	13.53	3.93	13.41	4.22	13.29	4.52
45	14.35	1.98	14.00	2.41	13.64	2.84	13.41	3.13	13.05	3.55	12.82	3.84	12.58	4.13

◆ ZHBW166A0 [HM161M U33] / ZHBW168A0 [HM163M U33]

Outdoor Temperature [°C DB]	Water flow rate 46.0 LPM													
	LWT 7 °C		LWT 10 °C		LWT 13 °C		LWT 15 °C		LWT 18 °C		LWT 20 °C		LWT 22 °C	
	TC	COP	TC	COP	TC	COP	TC	COP	TC	COP	TC	COP	TC	COP
10	15.00	3.85	16.43	4.23	17.87	4.60	18.83	4.85	20.26	5.23	21.22	5.48	22.17	5.73
20	15.40	3.31	16.26	3.70	17.12	4.09	17.70	4.35	18.56	4.74	19.13	5.00	19.70	5.26
30	15.80	2.77	16.09	3.17	16.37	3.57	16.57	3.84	16.85	4.25	17.04	4.51	17.23	4.78
35	16.00	2.50	16.00	2.91	16.00	3.32	16.00	3.59	16.00	4.00	16.00	4.27	16.00	4.55
40	16.20	2.23	16.00	2.63	15.80	3.02	15.66	3.29	15.46	3.68	15.32	3.95	15.19	4.21
45	16.40	1.96	16.00	2.34	15.59	2.73	15.32	2.98	14.92	3.37	14.65	3.62	14.38	3.88

Note

1. DB : Dry bulb temperature(°C), LWT : Leaving water temperature(°C), LPM : Liters per minute (ℓ/min)
2. TC : Total capacity(kW), COP : Coefficient of performance (kW/kW)
3. Direct interpolation is permissible. Do not extrapolate.
4. Measuring procedure follows EN-14511.
 - Rated values are based on standard conditions, and it can be found on specifications.
 - Above table values may not be matched according to installation condition. Except for rated value, the performance is not guaranteed.
 - In accordance with the test standard(or nations), the results may vary.

6. Performance Data

6.2 Heating Operation

■ Maximum Heating Capacity (Include defrost effect)

◆ ZHBW056A0 [HM051M U43]

Outdoor Temperature [°C DB]	Water flow rate 15.8 LPM								Water flow rate 9.9 LPM				Water flow rate 7.9 LPM			
	LWT 30 °C		LWT 35 °C		LWT 40 °C		LWT 45 °C		LWT 50 °C		LWT 55 °C		LWT 60 °C		LWT 65 °C	
	TC	COP	TC	COP	TC	COP	TC	COP	TC	COP	TC	COP	TC	COP	TC	COP
-25	3.79	1.88	3.67	1.75	3.54	1.63	3.42	1.50	-	-	-	-	-	-	-	-
-20	4.22	2.51	4.09	2.01	3.96	1.86	3.83	1.72	3.70	1.57	-	-	-	-	-	-
-15	4.66	2.42	4.52	2.27	4.38	2.10	4.25	1.93	4.11	1.77	3.97	1.60	-	-	-	-
-7	5.50	3.18	5.50	2.99	5.50	2.79	5.50	2.60	5.50	2.41	5.50	2.21	5.50	2.02	-	-
-4	5.50	3.36	5.50	3.14	5.50	2.93	5.50	2.71	5.50	2.49	5.50	2.28	5.50	2.06	5.50	1.91
-2	5.50	3.51	5.50	3.25	5.50	3.04	5.50	2.83	5.50	2.63	5.50	2.42	5.50	2.21	5.50	2.01
2	5.50	3.52	5.50	3.45	5.50	3.25	5.50	3.04	5.50	2.83	5.50	2.63	5.50	2.42	5.50	2.21
7	5.50	4.84	5.50	4.50	5.50	4.16	5.50	3.82	5.50	3.49	5.50	2.70	5.50	2.59	5.50	2.47
10	5.50	5.14	5.50	4.78	5.50	4.42	5.50	4.06	5.50	3.70	5.50	3.35	5.50	2.99	5.50	2.63
15	5.50	6.12	5.50	5.66	5.50	5.20	5.50	4.73	5.50	4.27	5.50	3.81	5.50	3.35	5.50	2.88
18	5.50	6.45	5.50	5.96	5.50	5.48	5.50	4.99	5.50	4.50	5.50	4.01	5.50	3.53	5.50	3.04
20	5.50	6.67	5.50	6.17	5.50	5.66	5.50	5.16	5.50	4.65	5.50	4.15	5.50	3.65	5.50	3.14
35	5.50	8.31	5.50	7.68	5.50	7.05	5.50	6.43	5.50	5.80	5.50	5.17	5.50	4.54	5.50	3.91

◆ ZHBW076A0 [HM071M U43]

Outdoor Temperature [°C DB]	Water flow rate 20.1 LPM								Water flow rate 12.6 LPM				Water flow rate 10.0 LPM			
	LWT 30 °C		LWT 35 °C		LWT 40 °C		LWT 45 °C		LWT 50 °C		LWT 55 °C		LWT 60 °C		LWT 65 °C	
	TC	COP	TC	COP	TC	COP	TC	COP	TC	COP	TC	COP	TC	COP	TC	COP
-25	4.82	1.99	4.67	1.73	4.51	1.48	4.36	1.22	-	-	-	-	-	-	-	-
-20	5.38	2.47	5.21	1.98	5.05	1.77	4.88	1.56	4.72	1.35	-	-	-	-	-	-
-15	5.93	2.38	5.76	2.22	5.58	2.06	5.41	1.90	5.23	1.74	5.06	1.58	-	-	-	-
-7	7.00	3.15	7.00	2.96	7.00	2.77	7.00	2.58	7.00	2.38	7.00	2.19	7.00	2.00	-	-
-4	7.00	3.33	7.00	3.11	7.00	2.90	7.00	2.68	7.00	2.47	7.00	2.25	7.00	2.04	7.00	1.89
-2	7.00	3.51	7.00	3.21	7.00	3.01	7.00	2.81	7.00	2.60	7.00	2.40	7.00	2.19	7.00	1.99
2	7.00	3.52	7.00	3.42	7.00	3.21	7.00	3.01	7.00	2.81	7.00	2.60	7.00	2.40	7.00	2.19
7	7.00	4.69	7.00	4.50	7.00	4.16	7.00	3.82	7.00	3.47	7.00	2.68	7.00	2.57	7.00	2.45
10	7.00	5.14	7.00	4.78	7.00	4.42	7.00	4.05	7.00	3.69	7.00	3.33	7.00	2.96	7.00	2.60
15	7.00	6.02	7.00	5.57	7.00	5.12	7.00	4.67	7.00	4.21	7.00	3.76	7.00	3.31	7.00	2.86
18	7.00	6.34	7.00	5.87	7.00	5.39	7.00	4.92	7.00	4.44	7.00	3.96	7.00	3.49	7.00	3.01
20	7.00	6.56	7.00	6.07	7.00	5.57	7.00	5.08	7.00	4.59	7.00	4.10	7.00	3.60	7.00	3.11
35	7.00	8.17	7.00	7.56	7.00	6.95	7.00	6.33	7.00	5.72	7.00	5.10	7.00	4.49	7.00	3.88

◆ ZHBW096A0 [HM091M U43]

Outdoor Temperature [°C DB]	Water flow rate 25.9 LPM								Water flow rate 16.2 LPM				Water flow rate 12.9 LPM			
	LWT 30 °C		LWT 35 °C		LWT 40 °C		LWT 45 °C		LWT 50 °C		LWT 55 °C		LWT 60 °C		LWT 65 °C	
	TC	COP	TC	COP	TC	COP	TC	COP	TC	COP	TC	COP	TC	COP	TC	COP
-25	6.20	1.95	6.00	1.70	5.80	1.45	5.60	1.20	-	-	-	-	-	-	-	-
-20	6.91	2.45	6.70	1.96	6.49	1.75	6.28	1.54	6.06	1.33	-	-	-	-	-	-
-15	7.63	2.39	7.40	2.22	7.18	2.05	6.95	1.89	6.73	1.72	6.50	1.55	-	-	-	-
-7	9.00	3.09	9.00	2.90	9.00	2.71	9.00	2.53	9.00	2.34	9.00	2.15	9.00	1.96	-	-
-4	9.00	3.26	9.00	3.05	9.00	2.84	9.00	2.63	9.00	2.42	9.00	2.21	9.00	2.00	9.00	1.85
-2	9.00	3.51	9.00	3.15	9.00	2.95	9.00	2.75	9.00	2.55	9.00	2.35	9.00	2.15	9.00	1.95
2	9.00	3.52	9.00	3.35	9.00	3.15	9.00	2.95	9.00	2.75	9.00	2.55	9.00	2.35	9.00	2.15
7	9.00	4.70	9.00	4.18	9.00	3.88	9.00	3.59	9.00	3.29	9.00	2.66	9.00	2.53	9.00	2.40
10	9.00	4.76	9.00	4.44	9.00	4.13	9.00	3.81	9.00	3.50	9.00	3.18	9.00	2.87	9.00	2.55
15	9.00	6.07	9.00	5.60	9.00	5.13	9.00	4.67	9.00	4.20	9.00	3.73	9.00	3.27	9.00	2.80
18	9.00	6.39	9.00	5.90	9.00	5.41	9.00	4.92	9.00	4.43	9.00	3.93	9.00	3.44	9.00	2.95
20	9.00	6.61	9.00	6.10	9.00	5.59	9.00	5.08	9.00	4.58	9.00	4.07	9.00	3.56	9.00	3.05
35	9.00	8.23	9.00	7.60	9.00	6.97	9.00	6.33	9.00	5.70	9.00	5.07	9.00	4.43	9.00	3.80

Note

1. DB : Dry bulb temperature(°C), LWT : Leaving water temperature(°C), LPM : Liters per minute (ℓ/min)
2. TC : Total capacity(kW), COP : Coefficient of performance (kW/kW)
3. Direct interpolation is permissible. Do not extrapolate.
4. Measuring procedure follows EN-14511.
 - Rated values are based on standard conditions, and it can be found on specifications.
 - Above table values may not be matched according to installation condition. Except for rated value, the performance is not guaranteed.
 - In accordance with the test standard(or nations), the results may vary.
5. The shaded areas are not guaranteed continuous operation.

6. Performance Data

◆ ZHBW126A0 [HM121M U33] / ZHBW128A0 [HM123M U33]

Outdoor Temperature [°C DB]	Water flow rate 34.5 LPM								Water flow rate 21.6 LPM				Water flow rate 17.3 LPM			
	LWT 30 °C		LWT 35 °C		LWT 40 °C		LWT 45 °C		LWT 50 °C		LWT 55 °C		LWT 60 °C		LWT 65 °C	
	TC	COP	TC	COP	TC	COP	TC	COP	TC	COP	TC	COP	TC	COP	TC	COP
-25	8.75	2.13	8.50	1.85	8.25	1.58	8.00	1.30	-	-	-	-	-	-	-	-
-20	10.13	2.34	10.00	2.13	9.88	1.91	9.75	1.70	9.63	1.49	-	-	-	-	-	-
-15	11.50	2.55	11.50	2.40	11.50	2.25	11.50	2.10	11.50	1.95	11.50	1.80	-	-	-	-
-7	12.00	3.15	12.00	3.00	12.00	2.85	12.00	2.70	12.00	2.55	12.00	2.40	12.00	2.25	-	-
-4	12.00	3.36	12.00	3.17	12.00	2.97	12.00	2.78	12.00	2.59	12.00	2.39	12.00	2.20	12.00	2.05
-2	12.00	3.47	12.00	3.28	12.00	3.09	12.00	2.90	12.00	2.71	12.00	2.53	12.00	2.34	12.00	2.15
2	12.00	3.69	12.00	3.50	12.00	3.31	12.00	3.12	12.00	2.93	12.00	2.73	12.00	2.54	12.00	2.35
7	12.00	4.93	12.00	4.60	12.00	4.27	12.00	3.93	12.00	3.60	12.00	2.80	12.00	2.60	12.00	2.60
10	12.00	5.22	12.00	4.87	12.00	4.51	12.00	4.16	12.00	3.81	12.00	3.46	12.00	3.10	12.00	2.75
15	12.00	5.99	12.00	5.56	12.00	5.13	12.00	4.71	12.00	4.28	12.00	3.85	12.00	3.43	12.00	3.00
18	12.00	6.29	12.00	5.84	12.00	5.39	12.00	4.94	12.00	4.49	12.00	4.05	12.00	3.60	12.00	3.15
20	12.00	6.49	12.00	6.02	12.00	5.56	12.00	5.10	12.00	4.64	12.00	4.17	12.00	3.71	12.00	3.25
35	12.00	7.98	12.00	7.41	12.00	6.84	12.00	6.28	12.00	5.71	12.00	5.14	12.00	4.57	12.00	4.00

◆ ZHBW146A0 [HM141M U33] / ZHBW148A0 [HM143M U33]

Outdoor Temperature [°C DB]	Water flow rate 40.3 LPM								Water flow rate 25.2 LPM				Water flow rate 20.1 LPM			
	LWT 30 °C		LWT 35 °C		LWT 40 °C		LWT 45 °C		LWT 50 °C		LWT 55 °C		LWT 60 °C		LWT 65 °C	
	TC	COP	TC	COP	TC	COP	TC	COP	TC	COP	TC	COP	TC	COP	TC	COP
-25	9.25	2.08	9.00	1.80	8.75	1.53	8.50	1.25	-	-	-	-	-	-	-	-
-20	10.63	2.26	10.50	2.05	10.38	1.84	10.25	1.63	10.13	1.41	-	-	-	-	-	-
-15	12.00	2.45	12.00	2.30	12.00	2.15	12.00	2.00	12.00	1.85	12.00	1.70	-	-	-	-
-7	14.00	3.12	14.00	2.95	14.00	2.79	14.00	2.63	14.00	2.46	14.00	2.30	14.00	2.14	-	-
-4	14.00	3.30	14.00	3.10	14.00	2.90	14.00	2.70	14.00	2.50	14.00	2.30	14.00	2.10	14.00	1.95
-2	14.00	3.39	14.00	3.20	14.00	3.01	14.00	2.82	14.00	2.63	14.00	2.43	14.00	2.24	14.00	2.05
2	14.00	3.65	14.00	3.40	14.00	3.21	14.00	3.02	14.00	2.83	14.00	2.63	14.00	2.44	14.00	2.25
7	14.00	4.83	14.00	4.50	14.00	4.17	14.00	3.83	14.00	3.50	14.00	2.78	14.00	2.50	14.00	2.50
10	14.00	5.12	14.00	4.77	14.00	4.42	14.00	4.06	14.00	3.71	14.00	3.36	14.00	3.00	14.00	2.65
15	14.00	6.02	14.00	5.57	14.00	5.13	14.00	4.68	14.00	4.24	14.00	3.79	14.00	3.35	14.00	2.90
18	14.00	6.33	14.00	5.86	14.00	5.39	14.00	4.92	14.00	4.45	14.00	3.99	14.00	3.52	14.00	3.05
20	14.00	6.53	14.00	6.05	14.00	5.57	14.00	5.08	14.00	4.60	14.00	4.12	14.00	3.63	14.00	3.15
35	14.00	8.09	14.00	7.49	14.00	6.89	14.00	6.29	14.00	5.70	14.00	5.10	14.00	4.50	14.00	3.90

◆ ZHBW166A0 [HM161M U33] / ZHBW168A0 [HM163M U33]

Outdoor Temperature [°C DB]	Water flow rate 46.0 LPM								Water flow rate 28.8 LPM				Water flow rate 23.0 LPM			
	LWT 30 °C		LWT 35 °C		LWT 40 °C		LWT 45 °C		LWT 50 °C		LWT 55 °C		LWT 60 °C		LWT 65 °C	
	TC	COP	TC	COP	TC	COP	TC	COP	TC	COP	TC	COP	TC	COP	TC	COP
-25	10.50	1.96	10.00	1.70	9.50	1.44	9.00	1.18	-	-	-	-	-	-	-	-
-20	12.30	2.33	11.75	1.94	11.44	1.74	11.13	1.55	10.75	1.34	-	-	-	-	-	-
-15	14.10	2.70	13.50	2.18	13.38	2.05	13.25	1.92	13.13	1.78	13.00	1.65	-	-	-	-
-7	16.00	2.96	16.00	2.80	16.00	2.64	16.00	2.48	16.00	2.31	16.00	2.15	16.00	1.99	-	-
-4	16.00	3.18	16.00	2.98	16.00	2.79	16.00	2.59	16.00	2.40	16.00	2.20	16.00	2.01	16.00	1.79
-2	16.00	3.51	16.00	3.11	16.00	2.90	16.00	2.70	16.00	2.50	16.00	2.30	16.00	2.10	16.00	1.90
2	16.00	3.52	16.00	3.35	16.00	3.14	16.00	2.93	16.00	2.73	16.00	2.52	16.00	2.31	16.00	2.10
7	16.00	4.74	16.00	4.40	16.00	4.06	16.00	3.72	16.00	3.38	16.00	2.75	16.00	2.40	16.00	2.36
10	16.00	5.05	16.00	4.69	16.00	4.33	16.00	3.96	16.00	3.60	16.00	3.24	16.00	2.88	16.00	2.51
15	16.00	5.67	16.00	5.54	16.00	5.08	16.00	4.62	16.00	4.16	16.00	3.69	16.00	3.23	16.00	2.77
18	16.00	6.34	16.00	5.85	16.00	5.36	16.00	4.87	16.00	4.39	16.00	3.90	16.00	3.41	16.00	2.93
20	16.00	6.56	16.00	6.05	16.00	5.55	16.00	5.05	16.00	4.54	16.00	4.04	16.00	3.53	16.00	3.03
35	16.00	8.23	16.00	7.60	16.00	6.96	16.00	6.33	16.00	5.70	16.00	5.07	16.00	4.43	16.00	3.80

Note

1. DB : Dry bulb temperature(°C), LWT : Leaving water temperature(°C), LPM : Liters per minute (l/min)
2. TC : Total capacity(kW), COP : Coefficient of performance (kW/kW)
3. Direct interpolation is permissible. Do not extrapolate.
4. Measuring procedure follows EN-14511.
 - Rated values are based on standard conditions, and it can be found on specifications.
 - Above table values may not be matched according to installation condition. Except for rated value, the performance is not guaranteed.
 - In accordance with the test standard(or nations), the results may vary.
5. The shaded areas are not guaranteed continuous operation.

7. Electric Characteristics

■ Wiring of Main Power Supply and Equipment Capacity

1. Bear in mind ambient conditions (ambient temperature, direct sunlight, rain liquid, etc.) when proceeding with the wiring and connections
 2. The wire size is the minimum value for metal conduit wiring. The power cord size should be 1 rank thicker taking into account the line voltage drops. Make sure the power-supply voltage does not drop more than 10%.
 3. Specific wiring requirements should adhere to the wiring regulations of the region.
 4. Power supply cords of parts of appliances for outdoor use should not be lighter than polychloroprene sheathed flexible cord.
 5. Don't install an individual switch or electrical outlet to disconnect each of indoor unit separately from the power supply.
-

WARNING

- Follow ordinance of your governmental organization for technical standard related to electrical equipment, wiring regulations and guidance of each electric power company.
 - Make sure to use specified wires for connections so that no external force is imparted to terminal connections. If connections are not fixed firmly, it may cause heating or fire.
 - Make sure to use the appropriate type of overcurrent protection switch. Note that generated overcurrent may include some amount of direct current.
-

CAUTION

- Some installation site may require attachment of an earth leakage breaker. If no earth leakage breaker is installed, it may cause an electric shock.
 - Do not use anything other than breaker and fuse with correct capacity. Using fuse and wire or copper wire with too large capacity may cause a malfunction of unit or fire.
-

7. Electric Characteristics

Outdoor Unit	Phase / Volts / Hz	Voltage range
ZHBW056A0 [HM051M U43]	1 Ø / 220-240 V / 50 Hz	Min. : 198 Max. : 264
ZHBW076A0 [HM071M U43]		
ZHBW096A0 [HM091M U43]		
ZHBW126A0 [HM121M U33]	1 Ø / 220-240 V / 50 Hz	Min. : 198 Max. : 264
ZHBW146A0 [HM141M U33]		
ZHBW166A0 [HM161M U33]		
ZHBW128A0 [HM123M U33]	3 Ø / 380-415 V / 50 Hz	Min. : 342 Max. : 457
ZHBW148A0 [HM143M U33]		
ZHBW168A0 [HM163M U33]		

Backup Heater	Power Supply for Heater	
	Phase / Volts / Hz	Capacity (kW)
AHEH036A [HA031M E1]	1 Ø / 220-240 V / 50 Hz	3
AHEH066A [HA061M E1]		3+3

DHW Boost Heater	Power Supply for DHW Boost Heater	
	Phase / Volts / Hz	Capacity (kW)
Integral part of DHW tanks [OSHW-x00F(D)]	1 Ø / 220-240 V / 50 Hz	2.4

[Power Supply for Heat pump, Backup heater and DHW boost heater]

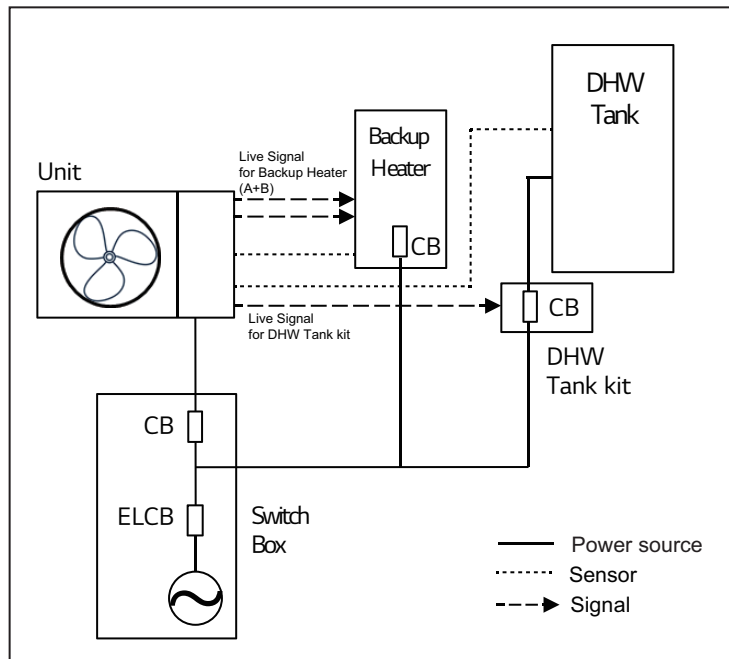

Note

1. Voltage supplied to the unit terminals should be within the minimum and maximum range.
2. Maximum allowable voltage unbalance between phase is 2%.

8. Operation Range

■ Cooling

Cooling

(Settings : Outlet temp. control / Fan coil unit used)

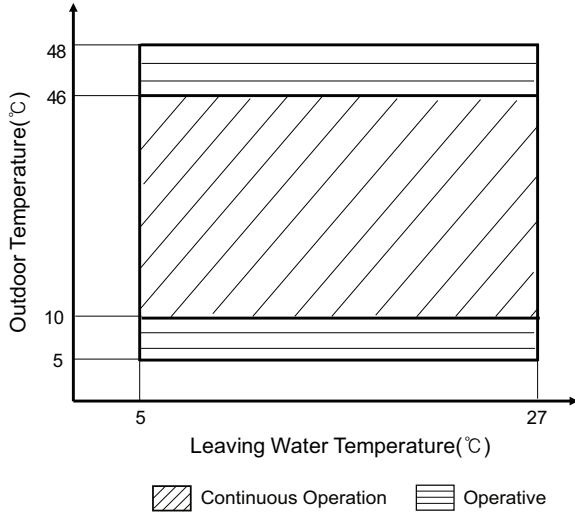

Cooling

(Settings : Inlet temp. control / Fan coil unit used)

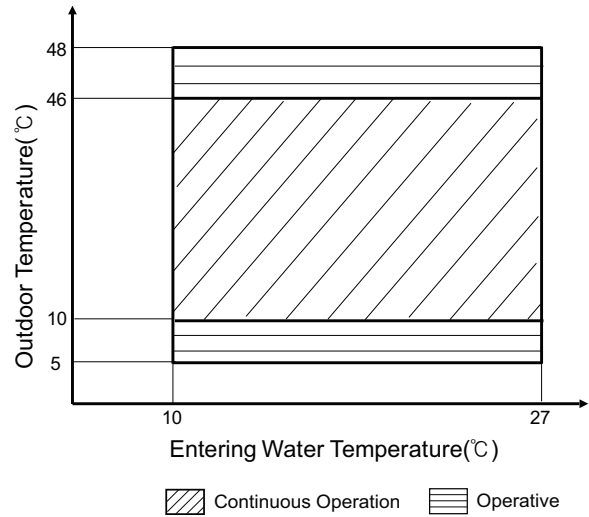

Cooling

(Settings : Outlet temp. control / Fan coil unit not used)

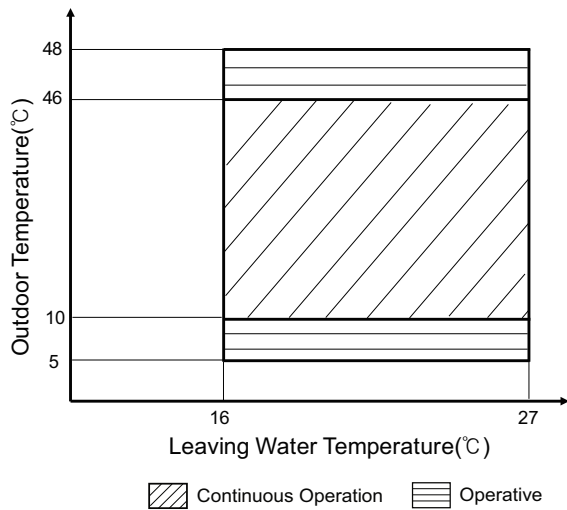

Cooling

(Settings : Inlet temp. control / Fan coil unit not used)

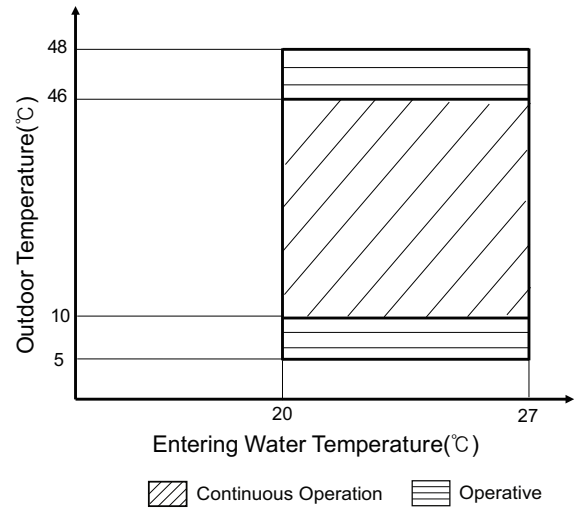

Note

- Continuous Operation : It is possible to operate continuously, but capacity is not guaranteed.
- Operative : It is not guaranteed continuous operation.

8. Operation Range

■ Heating

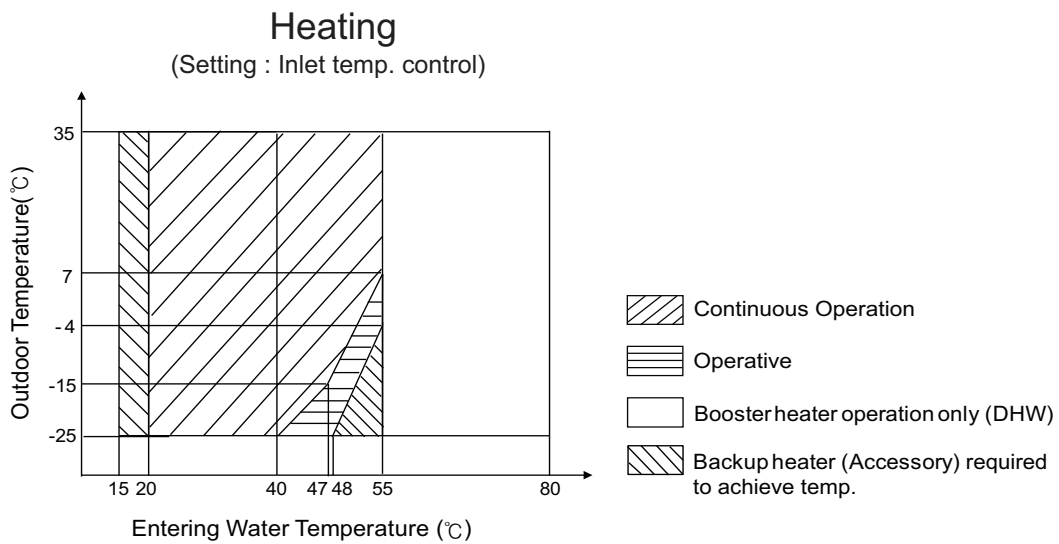
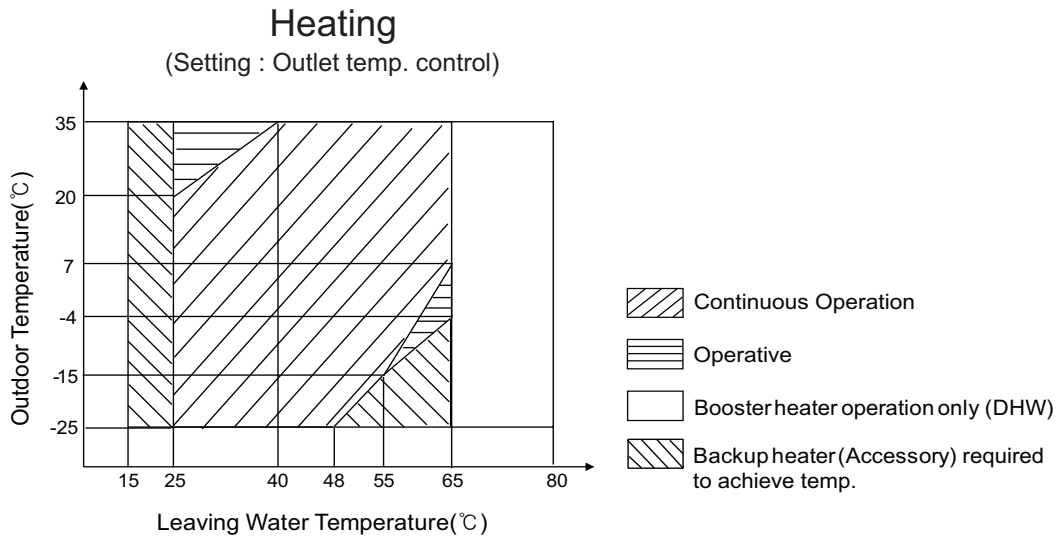

Note

- Continuous Operation : It is possible to operate continuously, but capacity is not guaranteed.
- Operative : It is not guaranteed continuous operation.
- DHW Heat pump operation : max. 55 °C
- DHW operation with electric heater : max. 80 °C

9. Sound levels

9.1 Sound power level

Note

1. Data is valid at diffuse field condition.
2. Reference acoustic intensity 0dB = $10E-6\mu W/m^2$
3. Sound power level is measured on the rated condition in the reverberation rooms. Refer to the Model Specifications for nominal conditions(Power source and Ambient temperature, etc)
4. Sound levels can be increased in accordance with installation and operating conditions.
5. Sound level will vary depending on a range of factors such as the construction (acoustic absorption coefficient) of particular installed place in which the equipment in installed.

Model	Sound Power Level [dB(A)]	
	Heating	
	Rated	Silent
ZHBW056A0 [HM051M U43]	60	58
ZHBW076A0 [HM071M U43]	60	58
ZHBW096A0 [HM091M U43]	60	58
ZHBW126A0 [HM121M U33]	63	61
ZHBW146A0 [HM141M U33]	63	61
ZHBW166A0 [HM161M U33]	63	61
ZHBW128A0 [HM123M U33]	63	61
ZHBW148A0 [HM143M U33]	63	61
ZHBW168A0 [HM163M U33]	63	61

ZHBW056A0 [HM051M U43]
 ZHBW076A0 [HM071M U43]
 ZHBW096A0 [HM091M U43]

ZHBW126A0 [HM121M U33], ZHBW128A0 [HM123M U33]
 ZHBW146A0 [HM141M U33], ZHBW148A0 [HM143M U33]
 ZHBW166A0 [HM161M U33], ZHBW168A0 [HM163M U33]

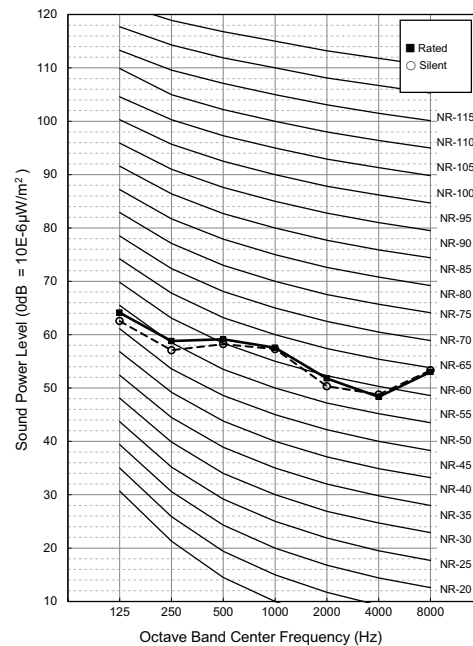
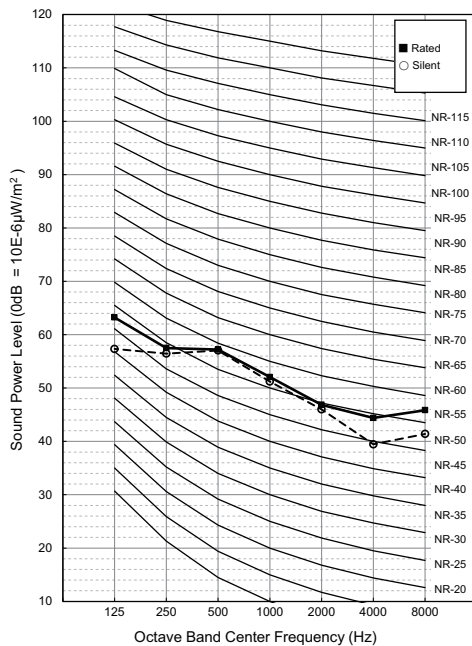

10. Water pump Capacity

The water pump is variable type which is capable to change flow rate, so it may be required to change default water pump capacity in case of noise by water flow. In most case, however, it is strongly recommended to set capacity as Maximum.

■ Pressure Drop

Capacity [kW]	Rated flow-rate [LPM]	Pump Head [m] (at rated flow-rate)	Product pressure drop [m] (Plate heat exchanger)	Serviceable Head [m]	Min. flow-rate [LPM] (Recommend)
5	14.37	7.5	0.2	7.3	15
7	20.12	7.3	0.3	7.0	
9	25.87	6.1	0.4	5.7	
12	34.50	9.8	0.8	9.0	20
14	40.25	9.3	1.1	8.2	
16	46.00	9.0	1.4	7.6	

Note

- To secure enough water flow rate, do not set water pump capacity as Minimum. It can lead unexpected flow rate error CH14.
- When installing the product, install additional pump in consideration of the pressure loss and pump performance.
- If flow-rate is low, overloading of product can occur.

THERMA VTM

Monobloc Type

Design and installation

- 1. Alternative Refrigerant R32**
- 2. Select the Best Location**
- 3. Installation Space**
- 4. Water Control**
- 5. Lifting Method**
- 6. Installation**
- 7. Electrical Wiring**
- 8. Starting Operation**

1. Alternative Refrigerant R32

The refrigerant R32 has the higher efficiency and more friendly for environment in comparison with R410A. It has a lower GWP (Global Warming Potential) value, and higher efficiency than R410A. The Ozone Depletion Potential (ODP) of R32 is 0, and Global Warming Potential(GWP) is 675.

Refrigerant piping consists of copper/steel pipes, joints, and other fittings. All components must be selected and installed in conformity with the standards pertaining to the Refrigeration Safety Regulation. Same piping as for R410A can be used.

WARNING

- This product contains fluorinated greenhouse gases (Refrigerant type : R32). Do NOT emit refrigerant gases into the atmosphere.
 - The refrigerant R32 is Slightly Flammable gas. But it does not leak normally. If the refrigerant leaks in the installed place and contact with burning energy, it may cause fire, or a harmful gas.
 - If there are some leak, turn off any combustible devices, ventilate the installed place, and contact the dealer from which you purchased the unit. Do not use the unit until the refrigerant leaked is repaired.
 - Only use R32 as refrigerant. Other substances may cause explosions and accidents.
-

CAUTION

- The wall thickness of the piping should comply with the relevant local and national regulations for the designed pressure.
 - For high-pressure refrigerant, any unapproved pipe must not be used.
 - Do not heat pipes more than necessary to prevent them from softening.
-

2. Select the Best Location

Select space for installing unit, which will meet the following conditions:

- No direct thermal radiation from other heat sources
- No possibility of annoying neighbors by noise from unit
- No exposition to strong wind
- With strength which bears weight of unit
- With space for air passage and service work shown next
- Because of the possibility of fire, do not install unit to the space where generation, inflow, stagnation, and leakage of combustible gas is expected.
- Avoid unit installation in a place where acidic solution and spray (sulfur) are often used.
- Do not use unit under any special environment where oil, steam and sulfuric gas exist.
- It is recommended to fence round the unit in order to prevent any person or animal from accessing the unit.
- If installation site is area of heavy snowfall, then the following directions should be observed.
 - Make the foundation as high as possible.
 - Fit a snow protection hood.
- Select installation location considering following conditions to avoid bad condition when additionally performing defrost operation.
 1. Install the unit at a place well ventilated and having a lot of sunshine in case of installing the product at a place with a high humidity in winter (near beach, coast, lake, etc).
 2. Performance of heating will be reduced and pre-heat time of the unit may be lengthened in case of installing the unit in winter at following location:
 - 1) Shade position with a narrow space
 - 2) Location with much humidity around.
 - 3) Location where liquid gathers since the floor is not even.
- When installing the unit in a place that is constantly exposed to a strong wind like a coast or on a high story of a building, secure a normal fan operation by using a duct or a wind shield.
 1. Install the unit so that its discharge port faces to the wall of the building. Keep a distance 300 mm or more between the unit and the wall surface.
 2. Supposing the wind direction during the operation season of the unit, install the unit so that the discharge port is set at right angle to the wind direction.

3. Installation Space

3.1 General considerations

- If an awning is built over the unit to prevent direct sunlight or rain exposure, make sure that heat radiation from the condenser is not restricted.
- Ensure that the spaces indicated by arrows around front, back and side of the unit.
- Do not place animals and plants in the path of the warm or cold air.
- Take the unit weight into account and select a place where noise and vibration are minimum.
- Select a place so that the air flow and noise from the unit do not disturb neighbors.
- Place that can sufficiently endure the weight and vibration of the outdoor unit and where even installation is possible.
- Place that has no direct influence of snow or rain.
- Place with no danger of extreme snowfall or icicle drop.
- Place without weak floor or base such as decrepit part of the building or with a lot of snow accumulation.

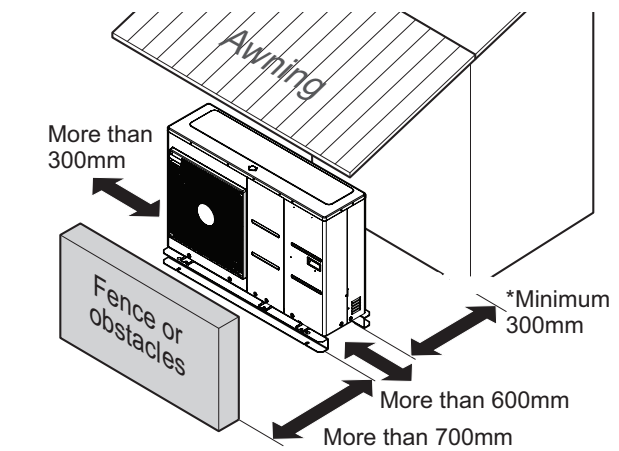

* Please secure the space to install the shut-off valve and strainer.

4. Water Control

4.1 Water quality

Water quality should be complied with EN 98/83 EC Directives.

Detailed water quality condition can be found in EN 98/83 EC Directives.

CAUTION

- If the product is installed at existing hydraulic water loop, it is important to clean hydraulic pipes to remove sludge and scale.
- Installing sludge strainer in the water loop is very important to prevent performance degrade.
- Chemical treatment to prevent rust should be performed by installer.
- It is strongly recommended to install an additional filter on the heating water circuit. Especially to remove metallic particles from the heating piping, it is advised to use a magnetic or cyclone filter, which can remove small particles. Small particles may damage the unit and will NOT be removed by the standard filter of the heat pump system.

4.2 Frost protection

In areas of the country where entering water temperatures drop below 0 °C, the water pipe must be protected by using an approved antifreeze solution. Consult your heat pump unit supplier for locally approved solutions in your area.

Calculate the approximate volume of water in the system. And add the water volume contained in the heat pump to this total volume.

Antifreeze type	Antifreeze mixing ratio (by volume)					
	0°C	-5°C	-10°C	-15°C	-20°C	-25°C
Methanol	0%	6%	12%	16%	24%	30%
Ethylene glycol	0%	12%	20%	30%	-	-
Propylene glycol	0%	17%	25%	33%	-	-

CAUTION

- Use only one of the above antifreeze.
- If a antifreeze is used, pressure drop and capability degradation of the system can be occurred.
- If one of antifreezes is used, corrosion can be occurred. So please add corrosion inhibitor.
- Please check the concentration of the antifreeze periodically to keep same concentration.
- When the antifreeze is used (for installation or operation), take care to ensure that antifreeze must not be touched.
- Ensure to respect all laws and norms of your country about antifreeze usage.

4. Water Control

4.3 Capacity correction factor by antifreeze

Antifreeze Type	Item	Antifreeze % by wt				
		10%	20%	30%	40%	50%
Methanol	Cooling	0.998	0.997	0.995	0.993	0.992
	Heating	0.995	0.990	0.985	0.979	0.974
	Pressure Drop	1.023	1.057	1.091	1.122	1.160
Ethylene glycol	Cooling	0.996	0.991	0.987	0.983	0.979
	Heating	0.993	0.985	0.977	0.969	0.961
	Pressure Drop	1.024	1.068	1.124	1.188	1.263
Propylene glycol	Cooling	0.993	0.987	0.980	0.974	0.968
	Heating	0.966	0.973	0.960	0.948	0.935
	Pressure Drop	1.040	1.098	1.174	1.273	1.405

◆ Correction factor of cooling capacity

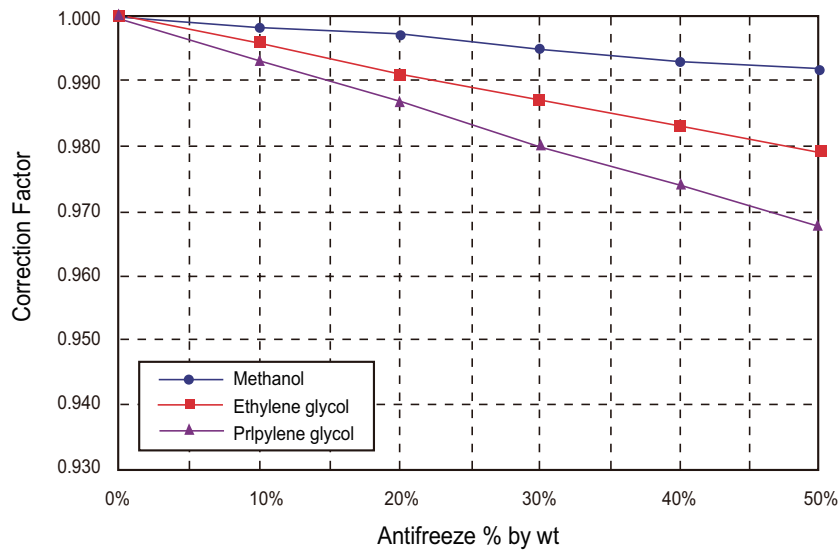

◆ Correction factor of heating capacity

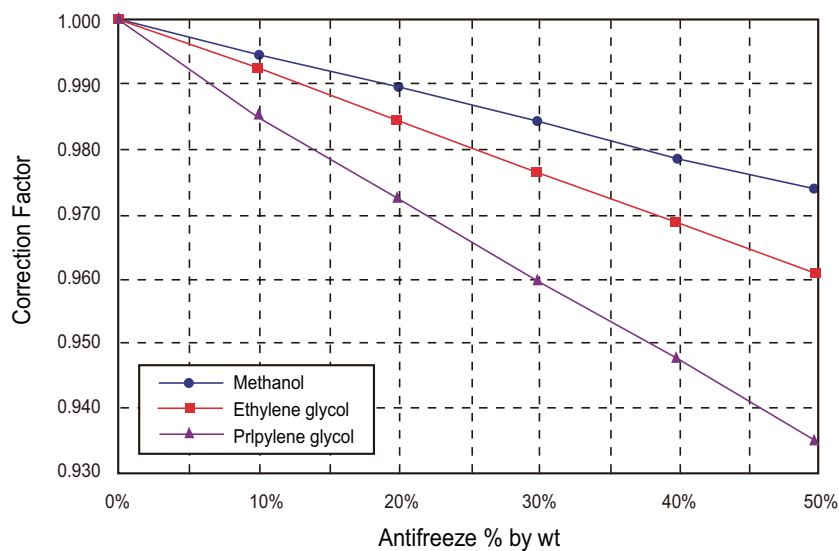

5. Lifting Method

- When carrying the suspended unit, pass the ropes under the unit and use the two suspension points each at the front and rear.
- Always lift the unit with ropes attached at four points so that impact is not applied to the unit.
- Attach the ropes to the unit at an angle of 40° or less.
- Use only accessories and parts which are of the designated specification when installing.

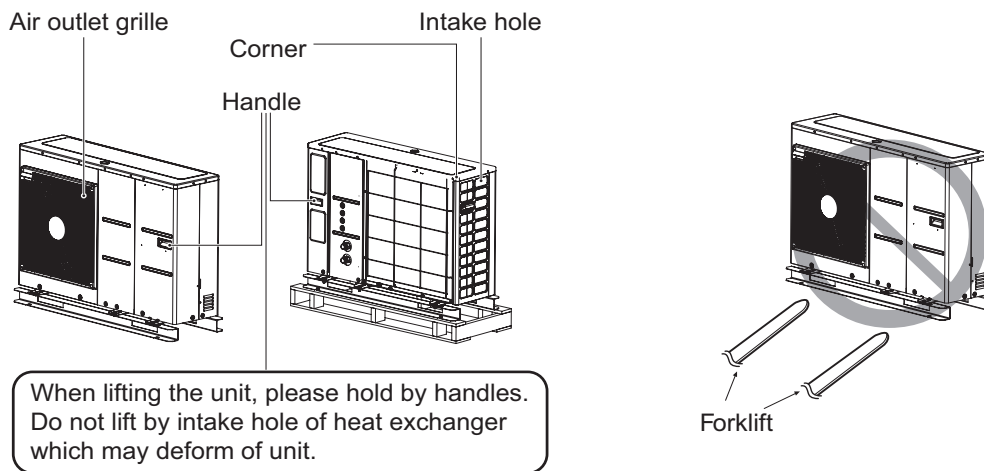
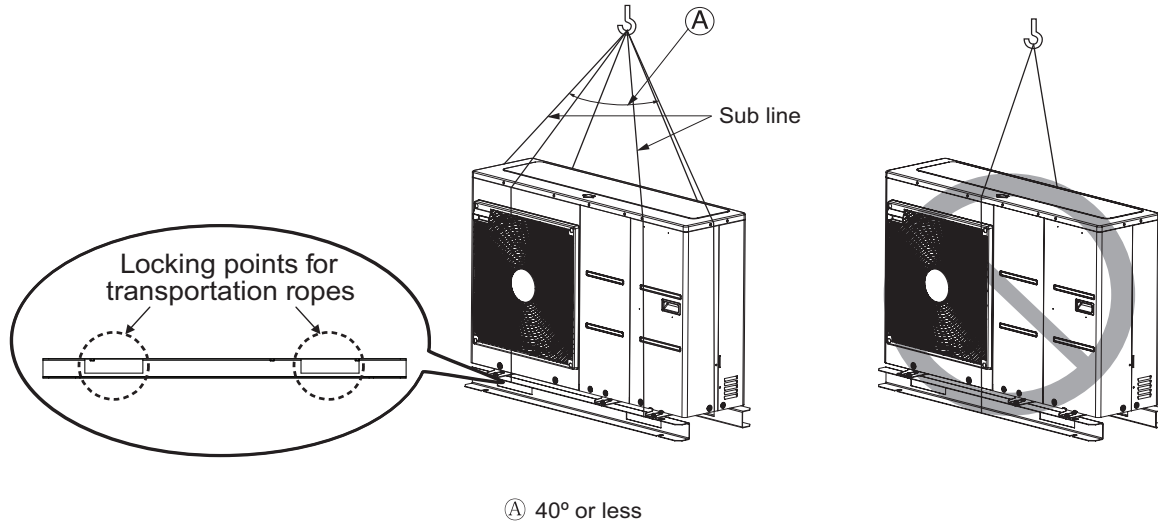

⚠ CAUTION

- Do not have only one person carry product if it is more than 20 kg.
- PP bands are used to pack some products. Do not use them as a mean for transportation because they are dangerous.
- Do not touch heat exchanger fins with your bare hands. Otherwise you may get a cut in your hands.
- Tear plastic packaging bag and scrap it so that children cannot play with it. Otherwise plastic packaging bag may suffocate children to death.
- When carrying in Outdoor Unit, be sure to support it at four points. Carrying in and lifting with 3-point support may make Outdoor Unit unstable, resulting in a fall.
- Place extra cloth or bodards in the locations where the casing comes in contact with the sling to prevent damage.
- Hoist the unit making sure it is being lifted at its center of gravity.

6. Installation

6.1 Foundation for Installation

- Check the strength and level of the installation ground so that the unit will not cause any operating vibration or noise after installation.
- Fix the unit securely by means of the foundation bolts.
(Prepare 4 sets of M12 foundation bolts, nuts and washers each which are available on the market.)
- It is best to screw in the foundation bolts until their length are 20mm from the foundation surface.

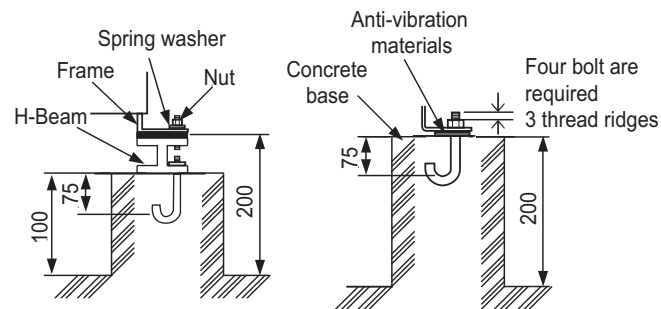
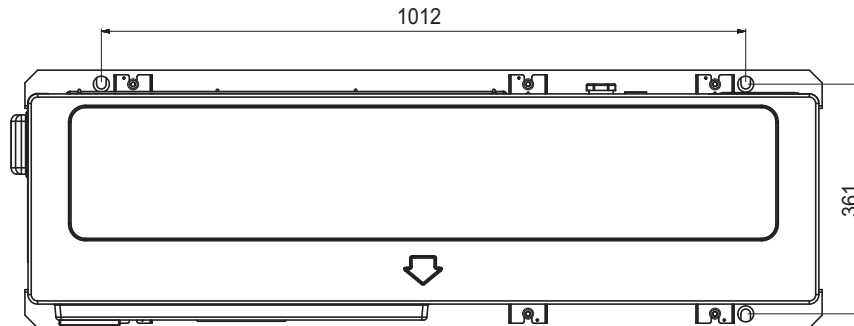

[Unit:mm]

Foundation bolt executing method

! WARNING

- Be sure to remove the Pallet (Wood Support) of the bottom side of the outdoor unit Base Pan before fixing the bolt. It may cause the unstable state of the outdoor settlement, and may cause freezing of the heat exchanger resulting in abnormal operations.
- Be sure to remove the Pallet (Wood Support) of the bottom side of the outdoor unit before welding. Not removing Pallet (Wood Support) causes hazard of fire during welding.

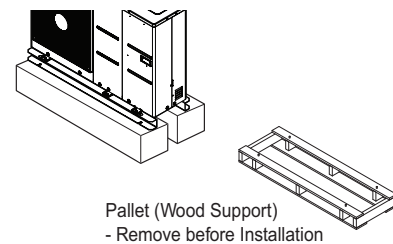

6. Installation

6.2 Water Piping and water Circuit Connection

6.2.1 General considerations

- Followings are should be considered before beginning water circuit connection.
- Service space should be secured.
- Water pipes and connections should be cleaned using water.
- Space for installing external water pump should be provided if internal water pump capacity is not enough for installation field.
- Never connect electric power while proceeding water charging.

6.2.2 Water piping and water circuit connection

1. Definition of terms are as follow :

- Water piping : Installing pipes where water is flowing inside the pipe.
- Water circuit connecting : Making connection between the unit and water pipes or between pipes and pipes. Connecting valves or elbows are, for example, in this category.

Configuration of water circuit is shown in 6.3 Installation Scenes. All connections should be complied with presented diagram.

2. While installing water pipes, followings should be considered :

- While inserting or putting water pipes, close the end of the pipe with pipe cap to avoid dust entering.
- When cutting or welding the pipe, always be careful that inner section of the pipe should not be defective. For example, no weldments or no burrs are found inside the pipe.
- Drain piping should be provided in case of water discharge by the operation of the safety valve. This situation can be happened when the internal pressure is over 3.0 bar and water inside the indoor unit will be discharged to drain hose.

3. While connecting water pipes, followings should be considered :

- Pipe fittings (e.g. L-shape elbow, T-shape tee, diameter reducer, etc) should be tightened strongly to be free from water leakage.
- Connected sections should be leakage-proof treatment by applying tefron tape, rubber bushing, sealant solution, etc.
- Appropriate tools and tooling methods should be applied to prevent mechanical breakage of the connections.
- Operation time of flow control valve(e.g. 3way valve or 2way valve) should be less than 90 seconds.
- Drain hose should be connected with drain piping.

WARNING

• Water condensation on the floor

If underfloor cooling is performed, it is very important to keep leaving water temperature higher than 16 °C. Otherwise, dew condensation can occur on the floor. If floor is in humid environment, do not set leaving water temperature below 18 °C.

• Water condensation on the radiator

While cooling operation, cold water may not flow to the radiator. If cold water enters to the radiator, dew generation on the surface of the radiator can be occurred. Use 2way-valve to block circuits from cooling operation.

• Drainage

While cooling operation, condensed dew can drop down to the bottom of the unit. The condensing water must be sufficiently drained from the unit and dissipated frost-free.

• Before starting water charging, these two shut-off valves should be assembled with water inlet and outlet pipe of the indoor unit.

7. Electrical Wiring

7.1 Dip switch information

Turn off electric power supply before setting DIP switch





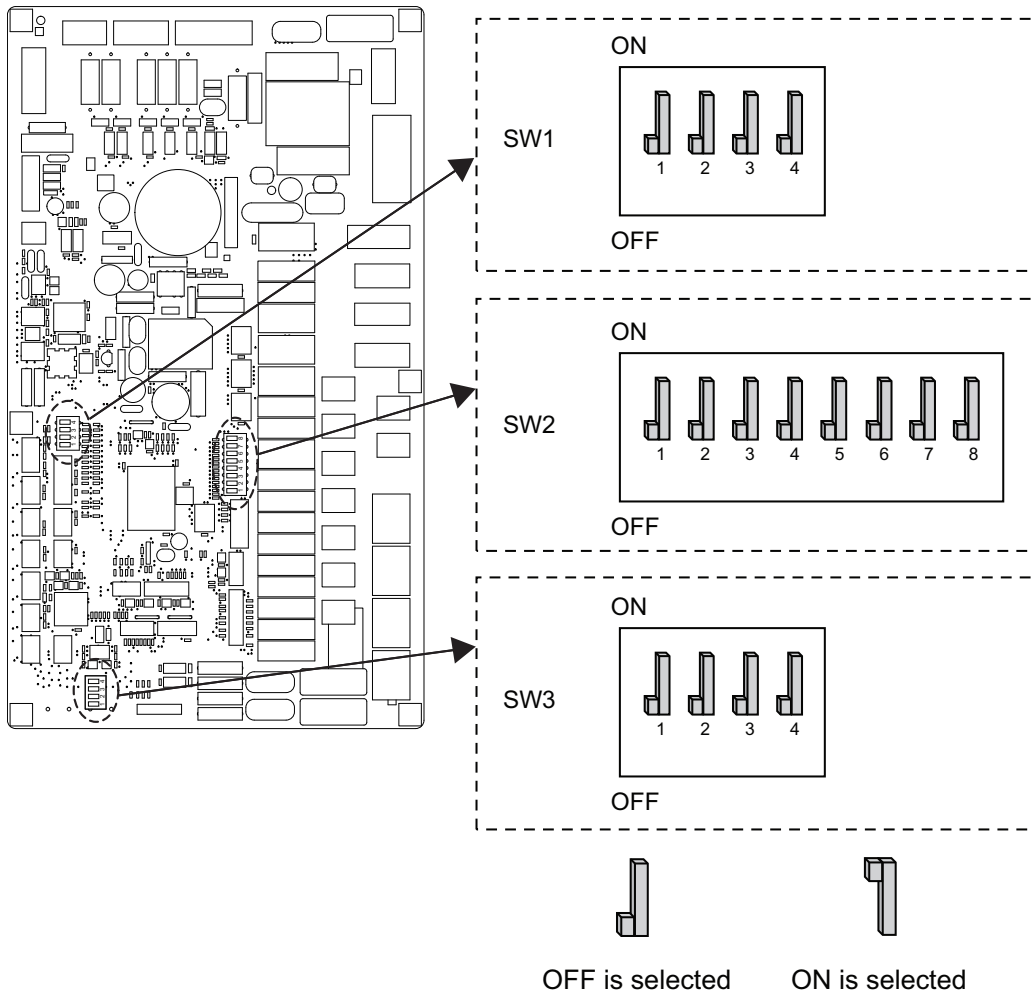







- Whenever adjusting DIP switch, turn off electric power supply to avoid electric shock.

■ Indoor PCB















7. Electrical Wiring

◆ Option Switch 1

































Description	Setting		Default
MODBUS Communication Type	1 	As Master	1 
	1 	As Slave	
Reserved	2  2 	Reserved	2 
Reserved	3  3 	Reserved	3 
Reserved	4  4 	Reserved	4 

◆ Option Switch 3

Description	Setting		Default
(Remote) Room air sensor	1 	LG Room sensor is not installed	1 
	1 	Remote sensor is installed	
Antifreeze mode	2 	Antifreeze mode not used	2 
	2 	Antifreeze mode used	
Reserved	3  3 	Reserved	3 
Reserved	4  4 	Not Use	4 

7. Electrical Wiring

◆ Option Switch 2

Description	Setting	Default
Role when central controller is equipped	1  As Master	1 
	1  As Slave	
Accessory installation information	  Heat pump is installed (Heating(Cooling) circuit only)	2  3 
	  Heat pump + DHW tank is installed	
	  Heat pump + DHW tank + Solar thermal system is installed	
	  DHW tank is installed (no Heating (Cooling) circuit)	
Cycle	4  Heating Only	4 
	4  Heating & Cooling	
Flow Switch Detection	5  Always	5 
	5  While water pump is on	
Selecting Backup Heater capacity	  Backup Heater is not used	6  7 
	  1Ø model : Half capacity is used 3Ø model : 1/3 capacity is used	
	  Unused	
	  Full capacity is used	
Thermostat installation information	8  Thermostat is NOT installed	8 
	8  Thermostat is installed	

7. Electrical Wiring

Outdoor PCB

UN4 Chassis

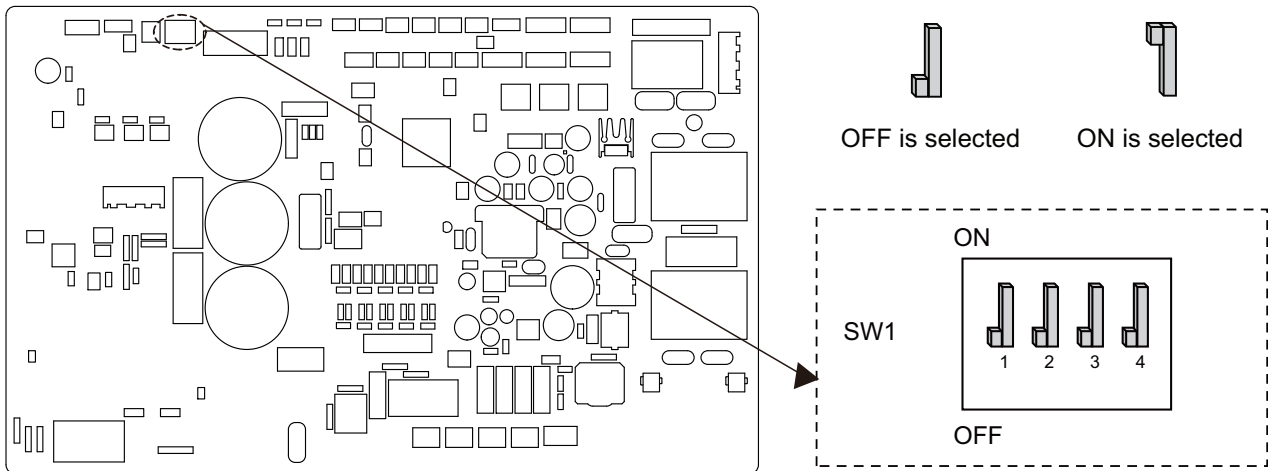

UN3 Chassis

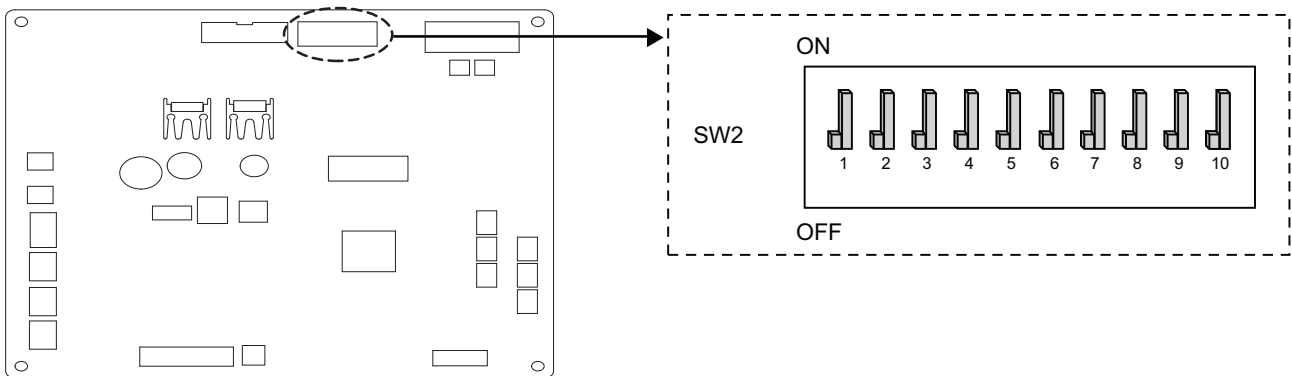

Peak Control

Description	Setting	Default
Peak Control	3 Max Mode	3
	3 Peak Control : To limit maximum current (Power saving)	

※ Only DIP-switch no.3 has a function. Others have no function.



Air Solution

LG Electronics Inc, 128, Yeoui-daero,
Yeongdeungpo-gu, Seoul, Korea
(07336)
<http://partner.lge.com>

Copyright © 2018 LG Electronics Inc.
All Rights Reserved.
Printed in Korea October / 2018

The air conditioners manufactured by LG have received ISO9001 certificate for quality assurance and ISO14001 certificate for environmental management system.
The specifications, designs, and information in this brochure are subject to change without notice.